

# CXA series

## USER MANUAL

CXA-12  
CXA-18S

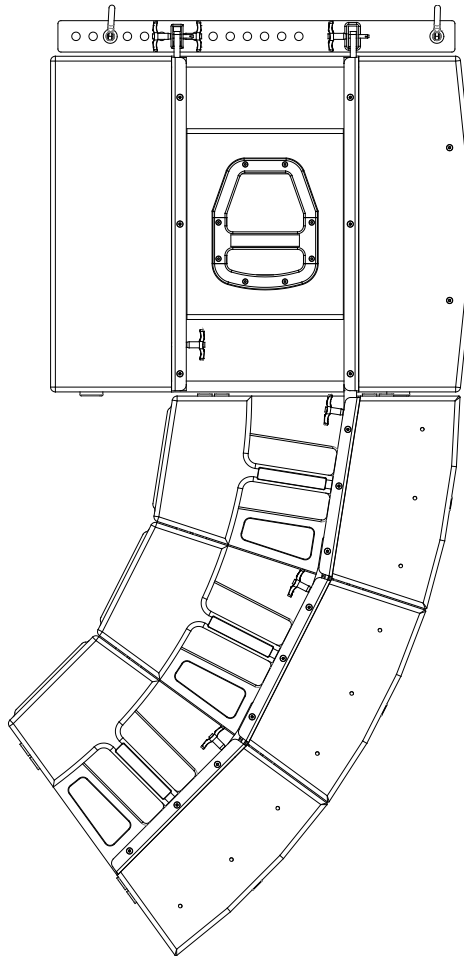

Lynx Pro Audio S.L.



CXA-12



CXA-18S

## Manufacturer



LYNX Pro Audio S.L.  
Calle 1 - Pol. Ind. Picassent  
E-46220 Picassent (Valencia)



**CE CERTIFICATION, EUROPEAN PRODUCT**

## INTRODUCTION

This manual describes the recommended installation procedure for the constant curvature line source CXA-12 in combination with the subwoofer CXA-18S.

The CXA is intended as a flexible solution for both fixed installations and touring where wide coverage is required from as few line array elements as possible. There is a "install version" available: CXA-12IN and CXA-18IN (page 27).

Designed to be flown either horizontally or vertically, this line source system can be used as a single element or a combination of a maximum of 4 cabinets in array configuration delivering a 72° coverage in the vertical plane. Our custom HF Multidriver Waveguide system delivers 100H x 18V precise coverage for a multitude of installations. Thanks to its careful construction it can also be installed for symmetrical HF dispersion.

The CXA Array models are self-powered (Class D) with switching power supply and 1400W of amplification each. They are also controlled by the latest generation of Digital Signal Processing with a DSP integrated in to each cabinet, optimizing all the system components and electronics, providing maximum system efficiency and total protection.

## CONTENTS

• SAFETY PRECAUTIONS	4
• SYSTEM OVERVIEW	
CXA-12	5
CXA-18S	6
BACK PANEL	7
CONNECTORS AND CONNECTIONS	8
• CONFIGURING THE DIGITAL SIGNAL PROCESSOR	
CONFIGURING THE DSP OPTIONS	12
CONFIGURATION PANEL	12
SELECT AND RUN PRESET	12
• ONLINE CONTROL SYSTEM	14
• RAINBOW 3D ACOUSTIC SIMULATION SOFTWARE	15
• HARDWARE AND ACCESSORIES	16
• APPLICATION EXAMPLES	17
• HOW TO USE THE FLYING FRAME ON CXA-12	19
• ASSEMBLY OF SV-CXA	21
• FITTING THE CXA-12 CABINETS TO THE FLYING FRAME	23
• FITTING THE CXA-18S CABINETS TO THE FLYING FRAME	24
• FITTING THE CXA-12 WITH CXA-18S CABINETS	25
• THE CEILING BRACKET	26
• CXA-12IN AND CXA-18IN CONFIGURATION	27
• CXA-IN FLOWN CONFIGURATION	28
• HARDWARE AND ACCESSORIES	30
• CERTIFICATIONS AND GUARANTEE	32

Before starting to use this device, please read this instruction manual carefully. Keep these instructions in the place where the equipment will be used and with easy access to them.



• **Electrical appliance**

The exclamation mark within a triangle identifies the presence of electricity. Use the system carefully without wet hands or feet. Avoid installing the speaker in wet or excessively humid places. Do not place material that contains liquid on or near the unit. Avoid dripping or splashing water or any liquid over the unit. Regularly check the condition of the cables and make sure these are not being walked on or pinched. Connect the speaker to bipolar, earthed mains. The mains plug must be connected to the appropriate protection (fuse or breaker). Connection to any other type of mains could result in an electrical shock and violate local electrical codes. CAUTION: DO NOT CONNECT OR DISCONNECT THE AC POWER CONNECTORS UNDER LOAD.



• **Heavy equipment**

Apply back protection when using the system. Avoid loading and unloading at heights.



• **Electrical shock risk**

The diagonal mark within a triangle identifies the presence of dangerous voltage. Do not open or handle the interior of the box. These parts are not to be adjusted by the user. For maintenance and/or repair please go to an authorized service centre. In order to reduce the risk of electric shock, disconnect from AC before plug in or unplugging Audio signal cables. Reconnect to AC only if all signal connections are made and secured. Never manipulate the ground type plug provided. The AC mains plugs should always remain accessible for operation. Unplug the loudspeaker during storms or when it's being used for a long time.



• **Hearing damage risk**

These systems can reproduce large quantities of sound pressure which can damage hearing. Take precautions if you are going to be near them for extended amounts of time and do not get too close.



• **Hanging / Flying**

Do not hang the cabinets from the handles or from any other part other than the designated hanging point. When flying this system please observe the technical and "Rainbow" software data carefully. Never exceed the maximum safe working loads or ignore the instructions included within this manual. Use Only flying accessories provided by Lynx Pro Audio S.L. Rigging must be always carried out by professionals.



• **Delicate Material**

Please ensure no foreign object or water enters the speaker. Only clean the unit with dry cloths. Do not use solvents.



• **Overheating / Fire risk**

To reduce the risk of the speaker over heating, avoid direct contact with sunlight. Avoid placing the unit close to heat inducing objects such as radiators. Do not cover the equipment in use and do not block any ventilation openings. Do not put naked flame, such as lighted candles, close or on top of the unit.



• **Electromagnetic and interefente emissions**

Avoid placing objects which through electromagnetic waves can damage the unit, such as mobile phones, lap tops, magnetic strip cards etc.

This system complies with normatives

EN 55103-1 (1)

EN 55103-2 (2)

(1) This device may not cause harmful interferences.

(2) This device may receive interference including interferences that may cause undesired working.



• **IMPORTANT NOTE**

This Equipment must be used in accordance with these instructions and by trained professional personnel only. This equipment should not be used in places with extreme tropical climates. Don't expose this apparatus to extreme humidity and or temperature values.



## SYSTEM OVERVIEW

- CXA-12

The CXA-12 enclosure is a constant curvature line array element designed for multiple configurations, with a maximum of 4 enclosures. High Output, self powered (class D switch mode power supply with PFC), constant curvature line array element.

- Technical Data:

Components:

- LF: 12", 2.5" voice coil, Malt Cross Cooling System
- MF/HF: custom Multidriver system with wave guide, 1.4" aluminium voice coil with titanium diaphragm

Frequency range: 60 Hz – 20 KHz (-10dB)

Frequency response: 70 Hz – 18 KHz (± 3dB)

Max SPL / Peak: 128 dB

Coverage angle: 100° H x 18 ° V

Power amplifier: 1400W Class D with switching power supply & PFC  
LF amplifier: 1 x 1400W

Processing: 96 KHz / 64 bit double-precision, DSP with FIR filter linear phase

Control: User control interface with 2.8" IPS screen

Control connections: Ethernet (OCS) / USB (DSP programming)

Input: Analog / AES3 optional

AC Power: 90 – 264V. 50/60 Hz with PFC

AC Connectors: 16A Neutrik powerCon TRUE1 TOP with looping output

Finish: Polyurea coating, high grade resistant paint

Material: 18 mm Premium birch plywood

Dimensions: 556 x 632 x 696 mm (H x W x D)

Weight: 45 kg (99 lbs)

- CXA-12 measurements

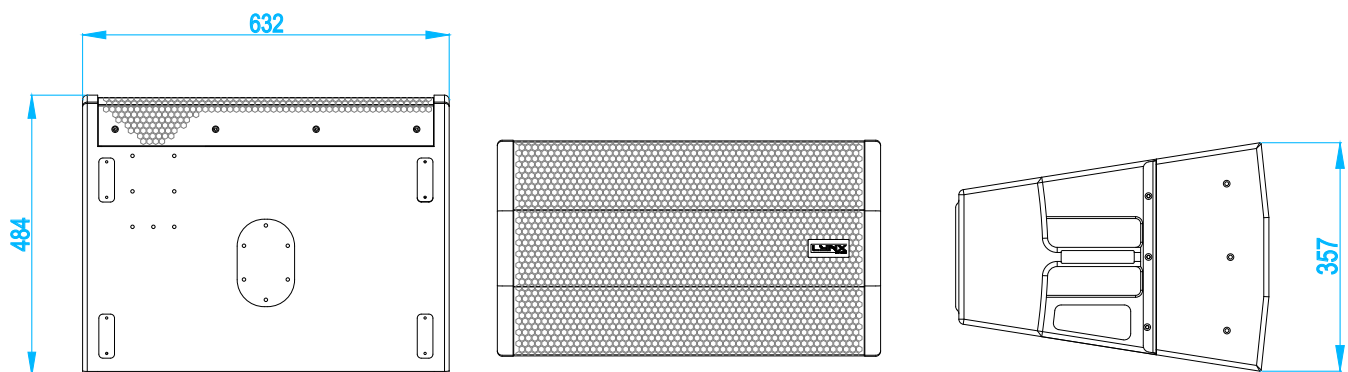

• CXA-18S

High output, self powered (class D switch mode power supply with PFC), omni-directional subwoofer cabinet. Consists of a 18" (4" ventilated voice coil) neodymium transducer. DSP controlled with 1400W amplification, 132dB SPL.

• Technical Data:

Components:

- LF: 18", 4" voice coil, Neodymium magnet assembly
- Frequency range: 30 Hz – 140 Hz (-10dB)
- Frequency response: 35 Hz – 125 Hz (± 3dB)
- Max SPL / Peak: 132 dB
- Coverage angle: Omnidirectional
- Power amplifier: 1400W Class D with switching power supply & PFC  
LF amplifier: 1 x 800W  
MF/ HF amplifier: 1 x 600W
- Processing: 96 KHz / 64 bit double-precision, DSP with FIR filter linear phase
- Control: User control interface with 2.8" IPS screen
- Control connections: Ethernet (OCS) / USB (DSP programming)
- Input: Analog / AES3 optional
- AC Power: 90 – 264V. 50/60 Hz with PFC
- AC Connectors: 16A Neutrik powerCon TRUE1 TOP with looping output
- Finish: Polyurea coating, high grade resistant paint
- Material: 15 mm Premium birch plywood
- Dimensions: 357 x 632 x 484 mm (H x W x D)
- Weight: 31 kg (68 lbs)

• CXA-18S measurements

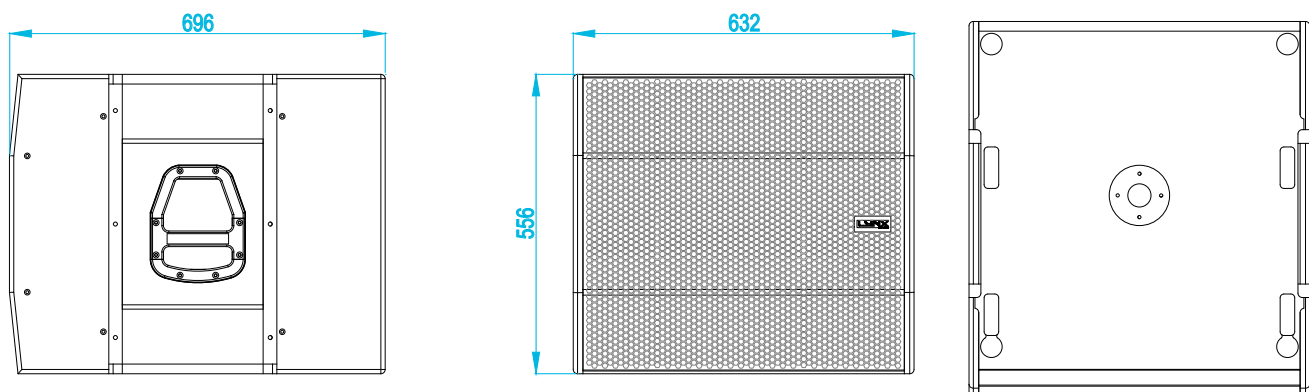

### CXA BACK PANEL panel

Both cabinets CXA-12 and CXA-18S have the same rear panel, including the connectors and digital control display.

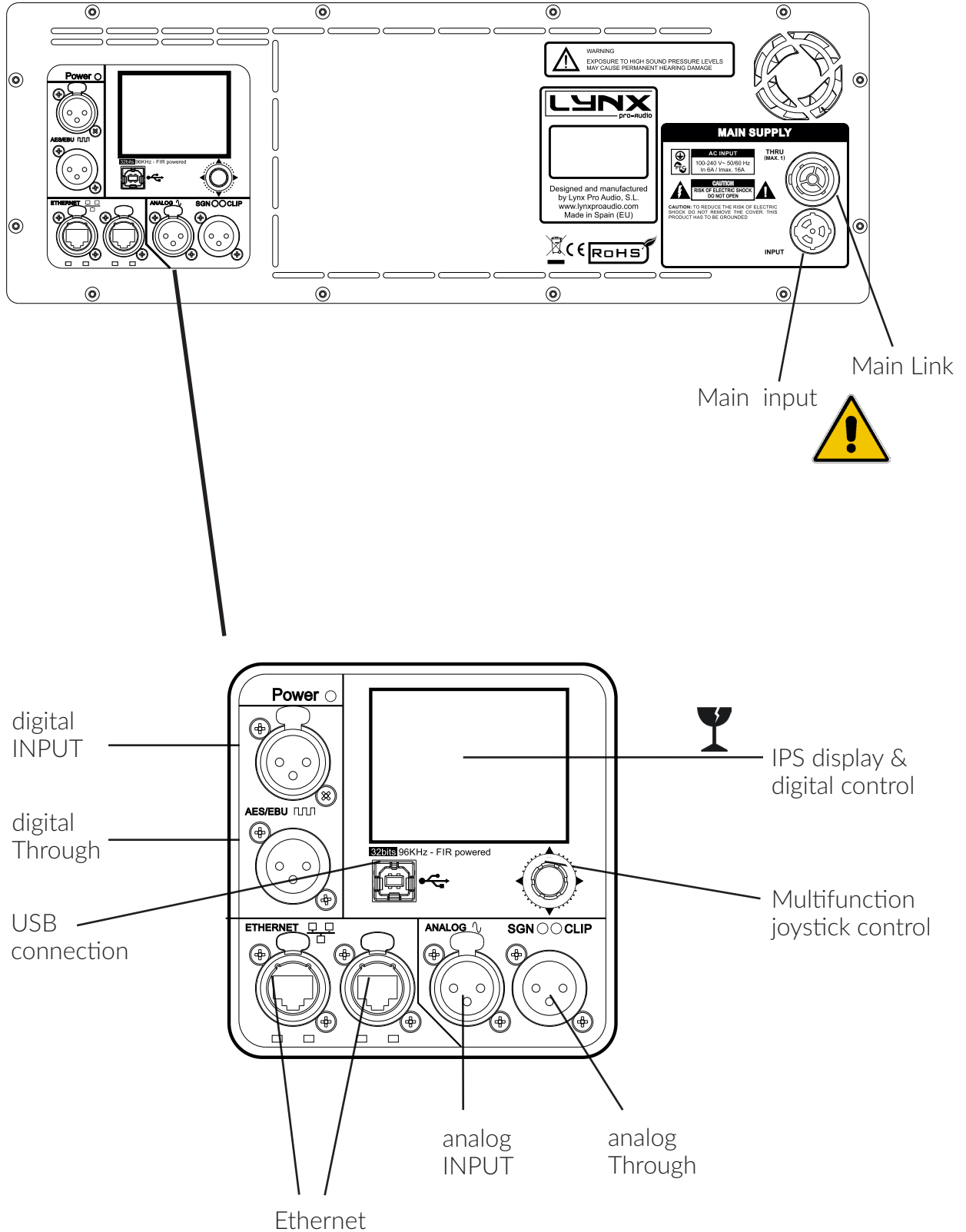

**CONNECTORS AND CONNECTIONS**



**CAUTION:** Do not connect or disconnect the AC Power connectors under load.

SOCKET POWERCON TRUE1

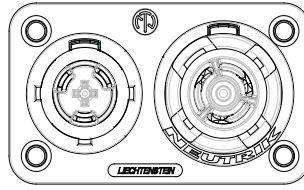

**INLET | OUTLET**

NAC3PX



**POWER IN**



NAC3FX-W or NKPF

(Connector)

**POWER OUT**

NAC3MX-W or NKPM

(Plug connector)

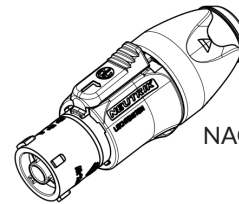

NAC3FX-W

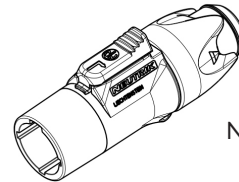

NAC3MX-W

**XLR SOCKET CONNECTORS**

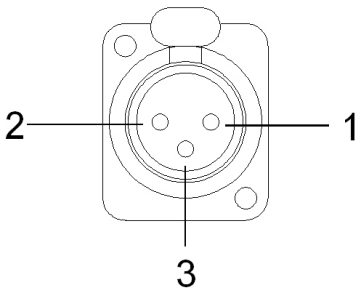

**INPUTS**

- 1.- EARTH
- 2.- LIVE (+)
- 3.- LIVE (-)

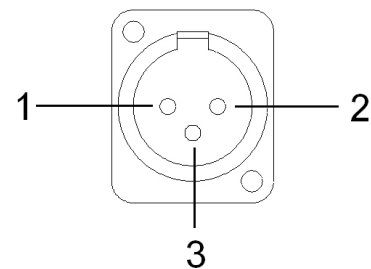

**OUTPUTS**

- 1.- EARTH
- 2.- LIVE (+)
- 3.- LIVE (-)

**XLR AERIAL CONNECTORS**

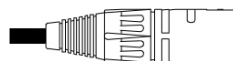

Connect to input

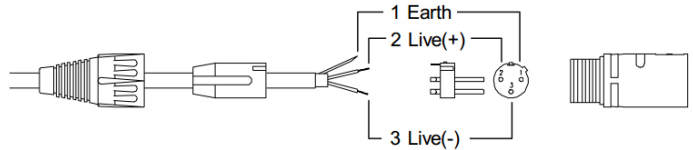

Connect to output

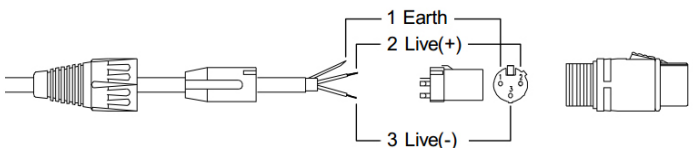

## CONNECTORS AND CONNECTIONS

- CONNECTION EXAMPLE (mono channel): four tops CXA-12 + two sub CXA-18S

This is the maximal CXA configuration, delivering a 72° coverage in the vertical plane. Total coverage 100°H x 72°V.

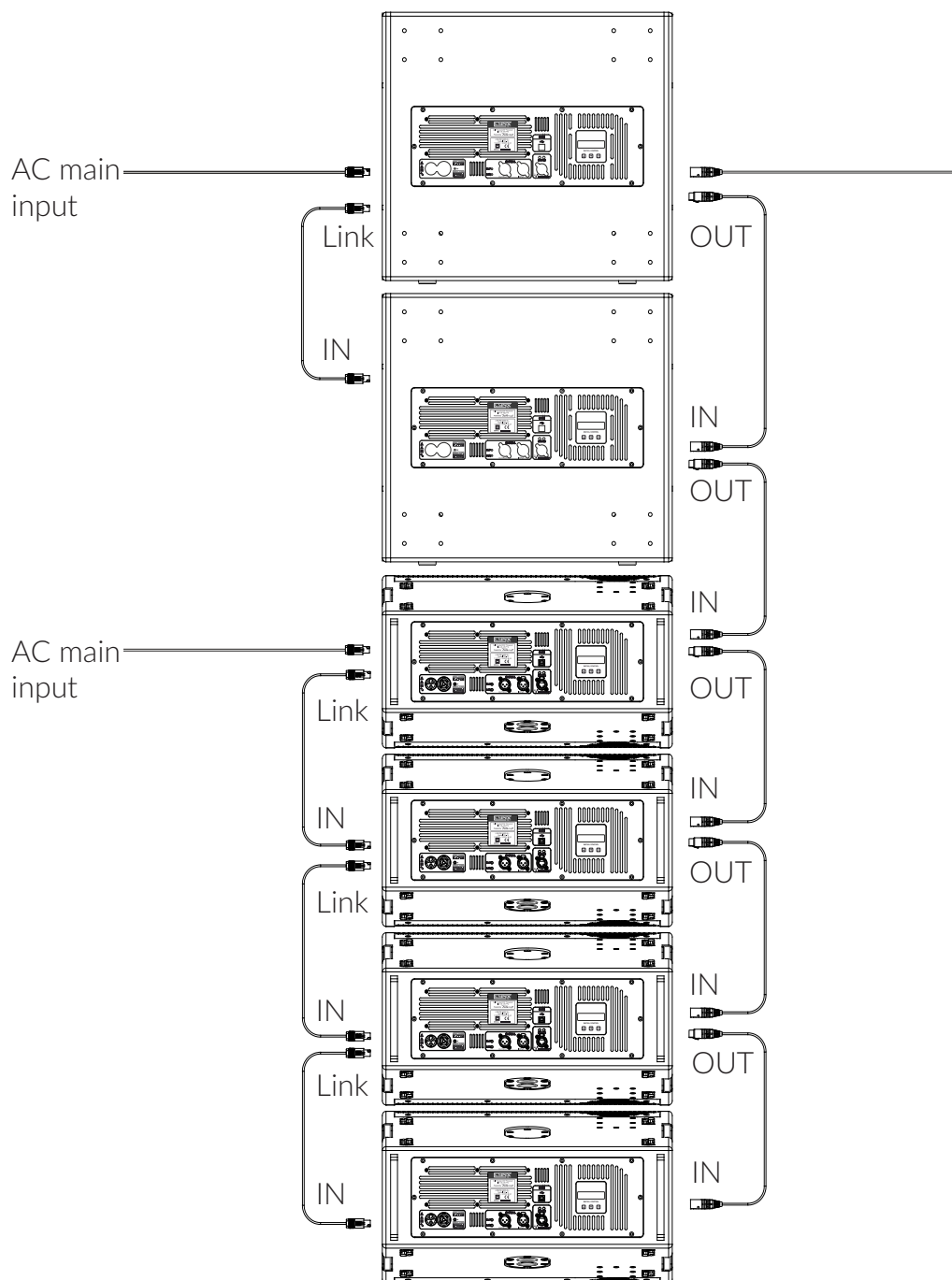

**CONNECTORS AND CONNECTIONS**

- STACKED CONNECTION EXAMPLE (mono channel): three tops CXA-12 + one sub CXA-18S

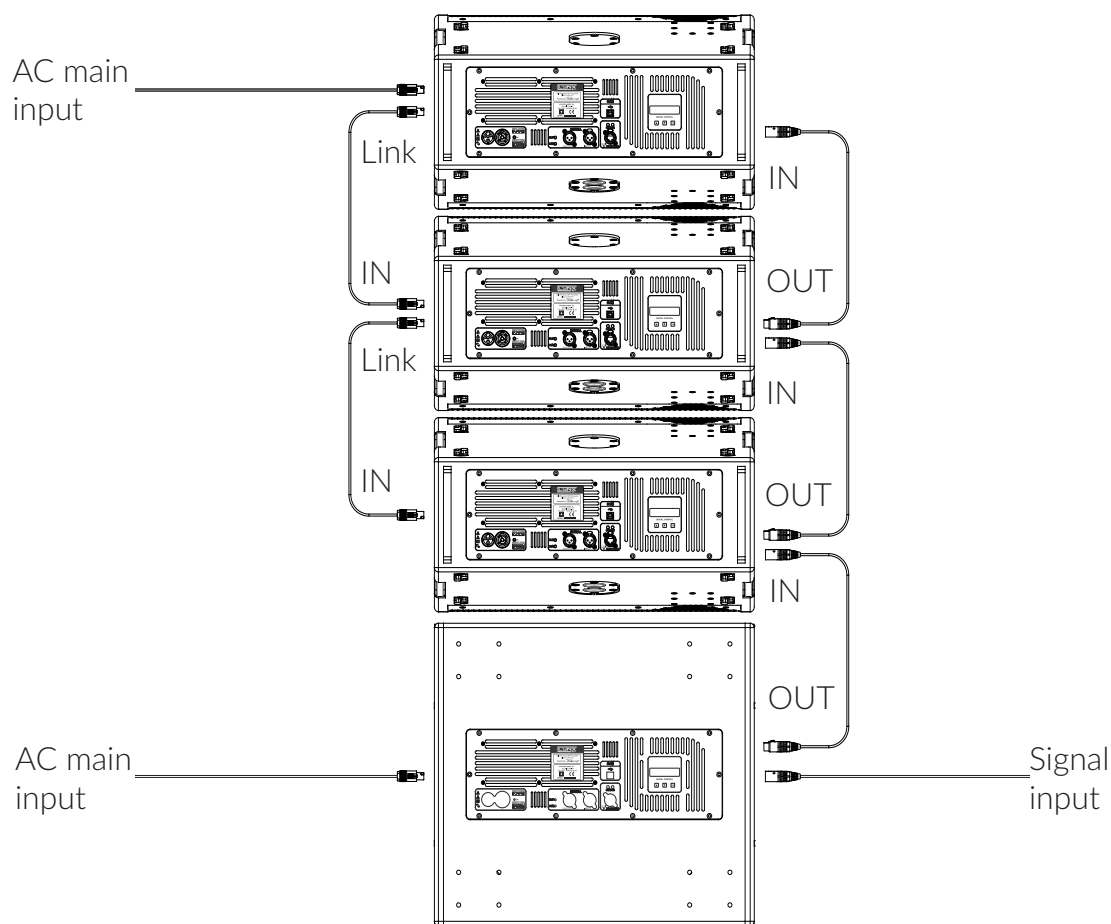

STACKED

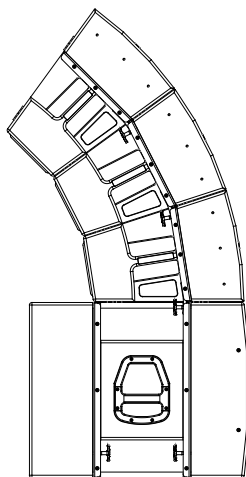

**CONNECTORS AND CONNECTIONS**

- FLOWN CONNECTION EXAMPLE (mono channel): three tops CXA-12 + one sub CXA-18S

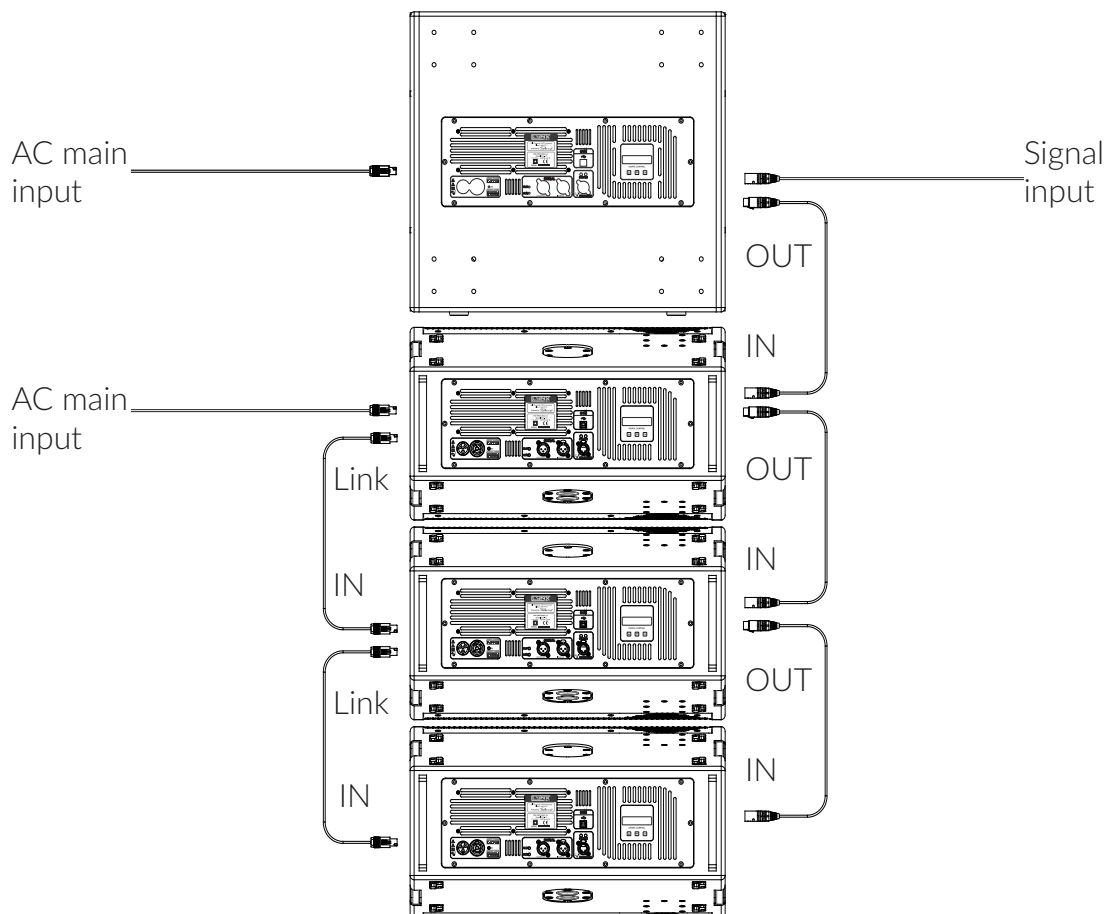

**FLOWN**

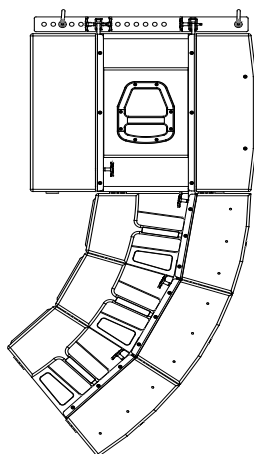

## FIR FILTERS

Finite Impulse Response (FIR) filters are used in the signal processing of the cabinets. FIR is a type of digital filter with linear phase characteristics. This frees system designers from the constraints of phase anomalies associated with analogue filters or their digital versions (IIR, Infinite Impulse Response). When properly used, FIR filtering can audibly improve a system's impulse response and reduce crossover interference.

## CONFIGURING THE CABINET DSP OPTIONS

On the back panel of the cabinet you will find the digital control area. From the compact joystick located below the screen you are able to configure the Basic adjustment functions of the internal DSP. Just move the joystick to select the icons on the left of the screen. You can enter into the following functions:

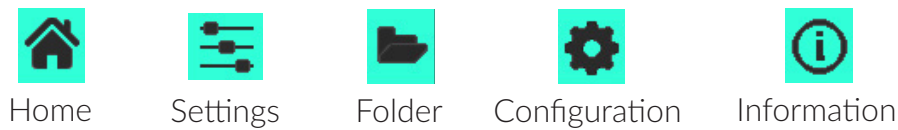

Please note that you must apply the desired configuration in each one cabinet and requires electrical power to work.

If changes are not made the display will automatically dim to avoid unnecessary light in situations where light is not wanted. To re-activate the light simply press the joystick.

## CONFIGURATION PANEL

On the main screen you can see the cabinet's input and output.

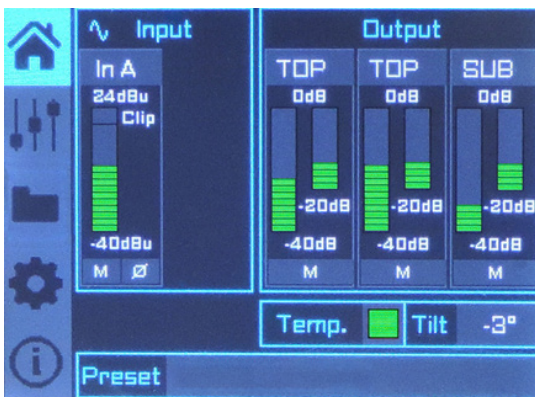

- **Input:**

You can see a vumeter with the input level and a clip signal.

- **Output:**

You have a vumeter with the output level (0 dBu is the amp's maximum level) You can check the compressor and control the dynamic activity.

On the second screen you can modify some parameters.

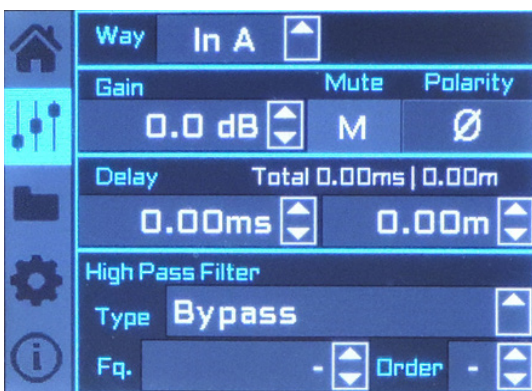

- **Gain**

- **Mute**

- **Polarity**

- **Delay**

- **High Pass Filter:** You can setup a High Pass filter selecting type, frequency and order.



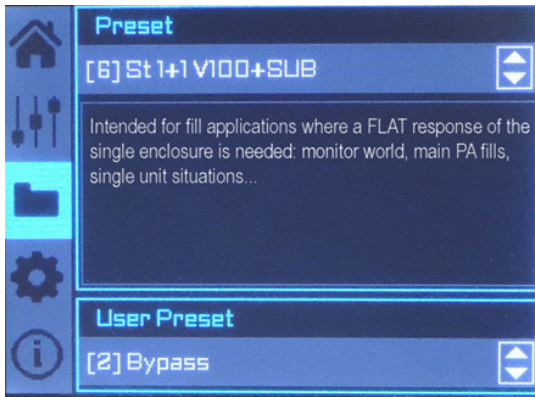

The folder screen shows you the name of the preset and its description.

Using the joystick you can change the preset.

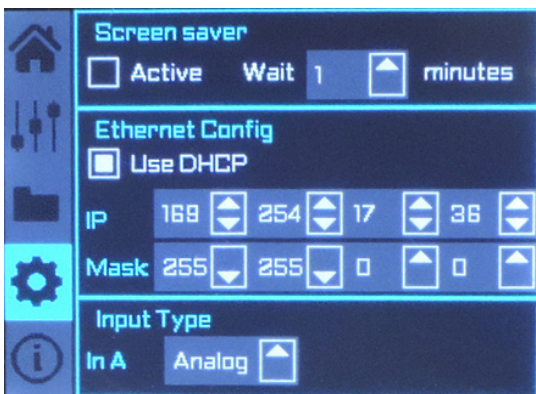

This screen is to configurate Ethernet. You can choose automatic or manual

You can also configure the screen saver.

And here you have the input selection. You can choose between analog or AES3 for channel 1 or channel 2.

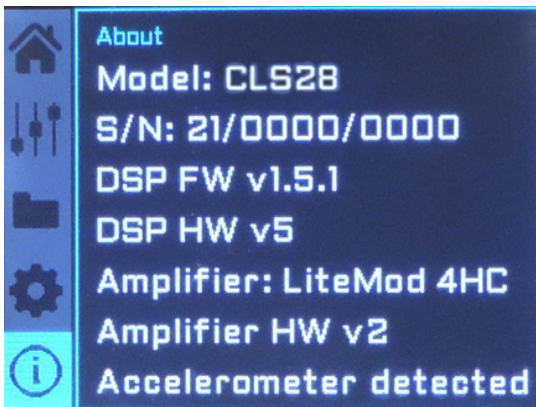

The last screen shows you some general information regarding the cabinet's components.

Here you can see the cabinet model, its serial number, DSP firmware and hardware versions, amp module model with hardware version, as well as the accelerometer status.

## ONLINE CONTROL SYSTEM

- Who is it for?

Users of Self powered DSP incorporated Lynx Pro Audio Cabinets where the user has requested the cabinets be supplied with the Ethernet Module kit.

- What is it for?

Obtain detailed information of cabinet behaviour and monitor the cabinet/s in real time. You can change the preset, gain, mute, polarity and phase. You can also activate the air absorption compensation and select the «SOLO» mode.

- How does it work?

Via Ethernet (cable or wireless). Once installed, the O.C.S. software automatically detects all the cabinets connected to the network and displays them in the O.C.S. window on the users PC.

- What does it show?

As well as displaying the cabinet model and IP address the O.C.S will be monitoring in real time and the user will be able to view RMS levels, Input clip, power module temperature, compression levels, air absorption compensation and cabinet angulation.

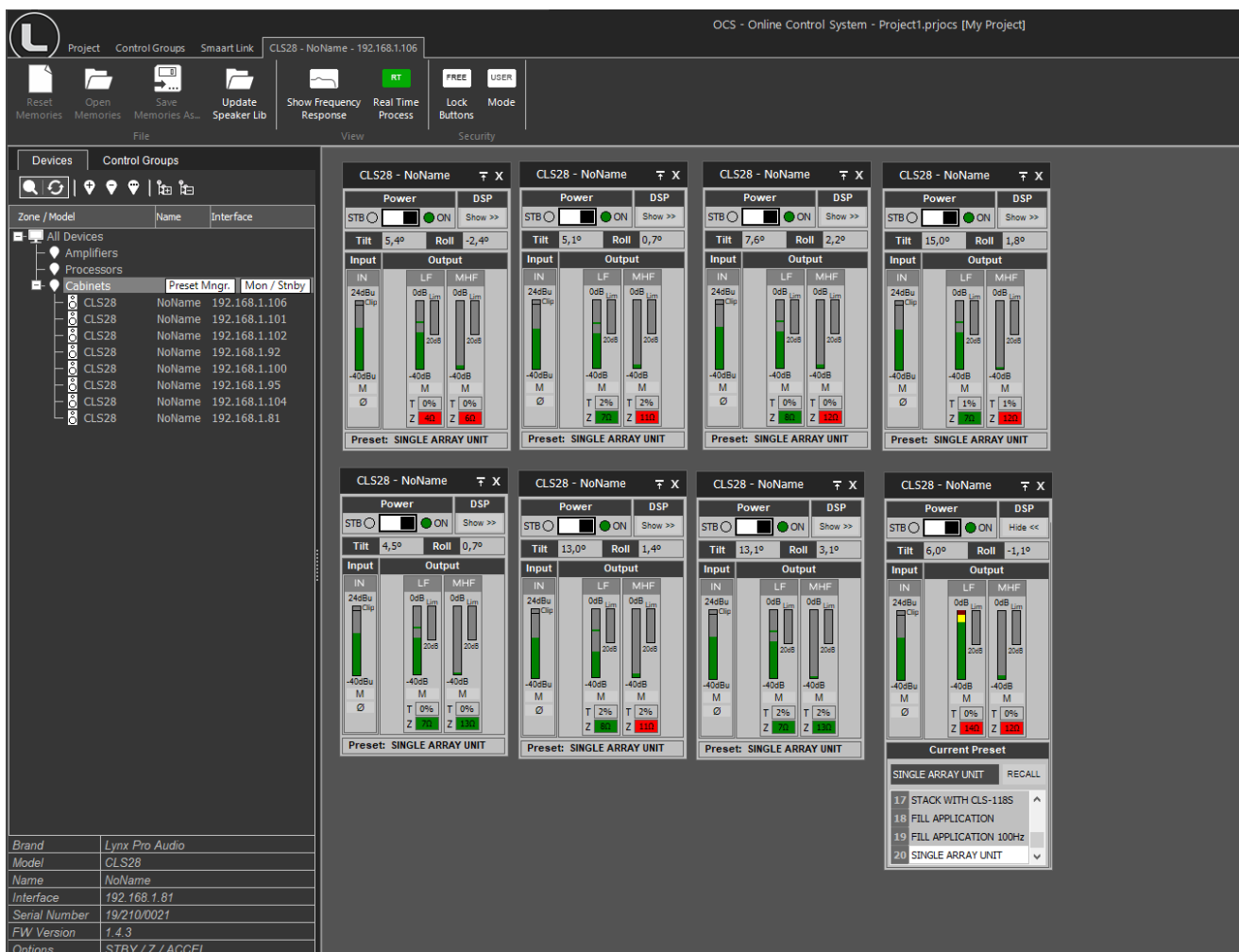

## RAINBOW 3D Acoustic Prediction Software

Lynx Pro Audio's R&D department is working on Rainbow 3D, a new acoustic simulation software with dynamic 3D features. With a sophisticated design, Rainbow 3D stands out for its speed, being able to provide a simulation in just a few seconds. It also provides algorithms for beam steering and optimizing the listening area.

- **Designed from scratch by professionals**

Rainbow 3D has been programmed from scratch by Lynx Pro Audio engineers, using new programming procedures that achieve an effective simulation with really low calculation time.

- **Multiple listening zones**

The program can simulate all Lynx Pro Audio's acoustic enclosures located in a 3D space, including the classic side, top and front views. It can also define multiple listening zones and allows offset positioning and symmetry. Blueprint images, textures and PNG format pictures can be imported.

- **Unlimited sound sources**

Allows the acoustic simulation for an unlimited number of sound sources and audio systems. You can place as many systems (subwoofers, line arrays, columns and individual boxes) as you desire. Also, the line arrays can be placed in stack or flown configuration.

- **Beam steering**

Rainbow 3D has the ability to add DSP processing to the simulation and uses algorithms to control the directivity (beam steering) in columns, without the need to tilt them physically, being able to divide the column into several beams that point to different zones.

- **Accurate optimization thanks to FIR filters**

Optimized algorithms are used in the listening area to improve the sound coverage and the frequency response. This feature can be executed in a matter of seconds. Additionally, the export of FIR coefficients can be performed with the optimization for later loading in the DSP via Ethernet or a USB device. In the near future direct communication with Lynx Pro Audio and OCS will be available.

- **Multiple measures and tools**

Likewise, the R&D department is developing multiple measurement and analysis tools for the calculated data. For example, the sound pressure curves (SPL) in the listening areas and the capture of virtual measurements that show the frequency response in the points of location indicated and added. Among other tools you will find autoplay and a wizard to set up different subwoofer arrangements.

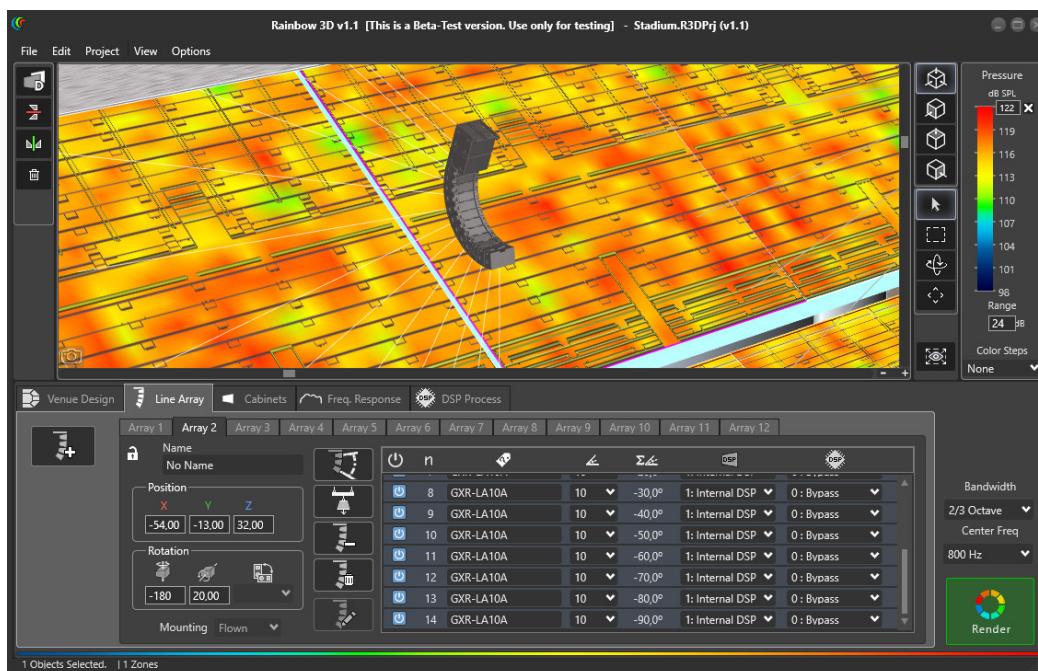

## HARDWARE AND ACCESSORIES

The CXA cabinets offer a variety of practical accessories to help use the system in a number of events, from touring applications to fixed installations, indoor and outdoor.



**BALL-PSR6**  
Ball pin with thread for CXA-12 and CXA-18S cabinets

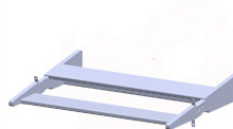

**ST-CXA**  
Special piece to stack CXA-12 cabinets



**SV-CXA**  
Flying frame designed for rigging a maximum of 2 sub CXA-18S with 4 CXA-12



**GR-18WKIT**  
Four wheel kit



**UBR-CXA12**  
Ceiling bracket for CXA-12

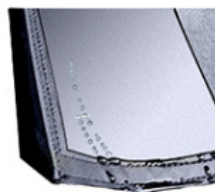

**FD-1CXA12NL**  
**FD-1CXA18SNL**  
Rain cover for the back panel of the CXA-12 or CXA-18S



**FC-3CXA12**  
Flight case to transport three CXA-12



**FD-CXA18S**  
Nylon protection for CXA-18S

## APPLICATION EXAMPLES

---

- For a multitude of applications:

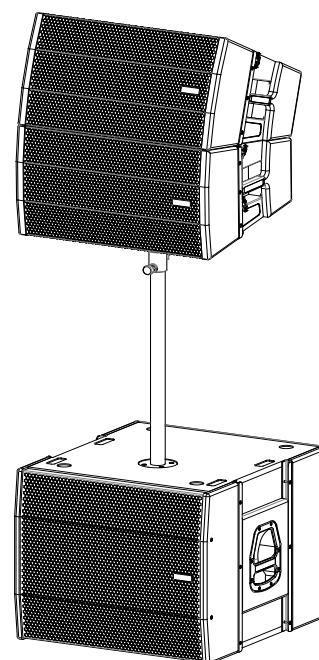
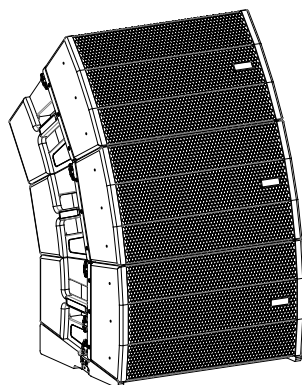
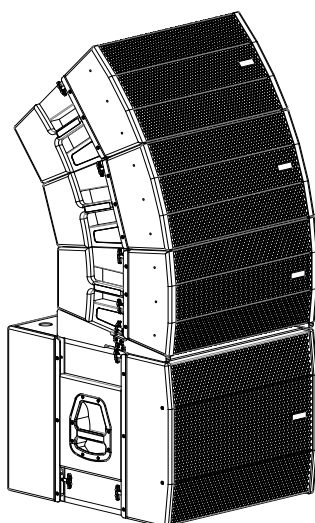
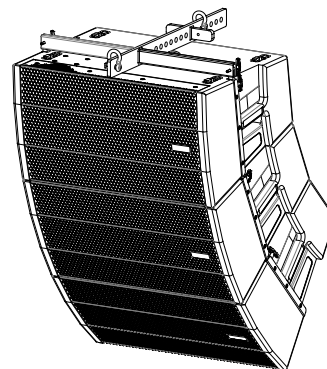
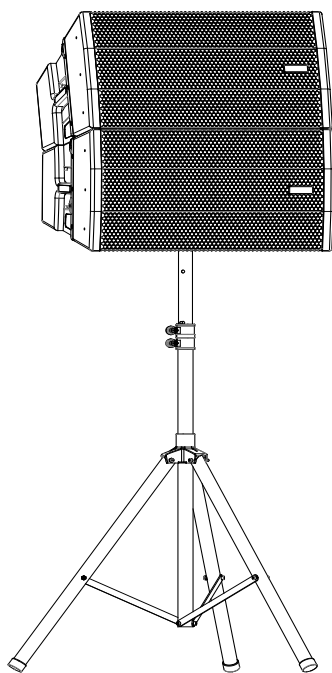
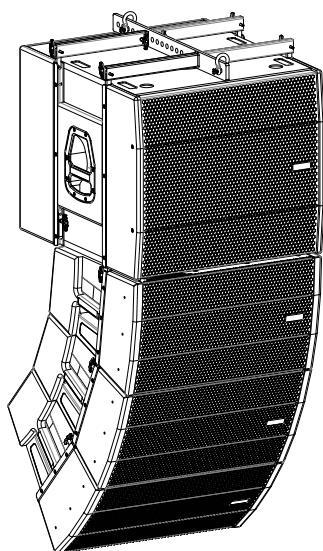



APPLICATION EXAMPLES

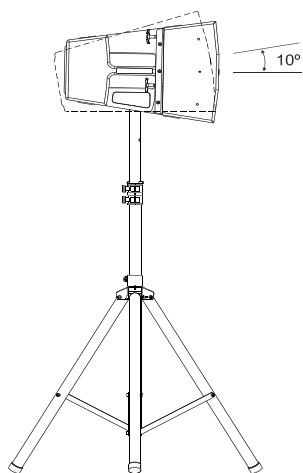

- 300 people. Coverage: 100°H x 18°V  
Freq. response: 70 Hz - 18 KHz

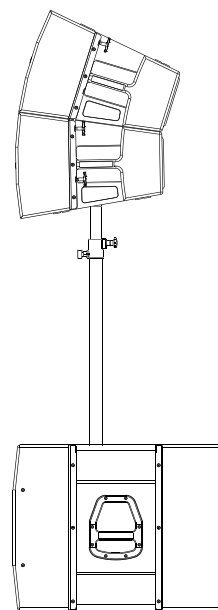

- 500 people. Coverage: 100°H x 36°V  
Freq. response: 35 Hz - 18 KHz

For applications with higher low-frequency demand add one sub unit CXA-18S per channel.

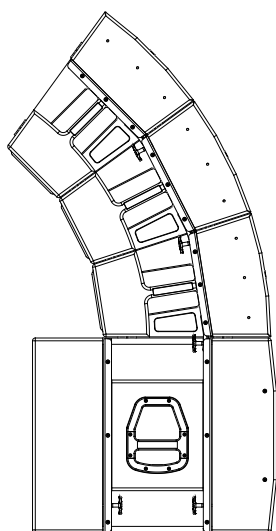

- 800 people. Coverage: 100°H x 54°V  
Freq. response: 35 Hz - 18 KHz

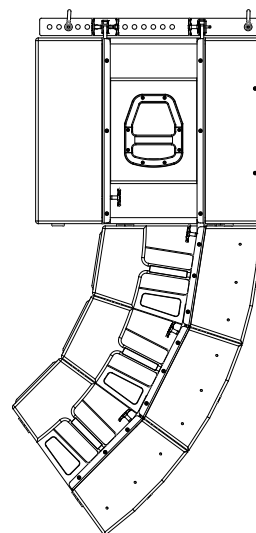

- 800 people. Coverage: 100°H x 72°V  
Freq. response: 35 Hz - 18 KHz

## HOW TO USE THE FLYING FRAME SV-CXA

- The flying system SV-CXA is constructed with steel. The flying frame is composed of an upper support with a fixed transversal front piece and an adjustable transversal rear piece. All the cabinets are hung from this flying frame, one beneath the other correspondingly.

When using the flying frame with the CXA-12 enclosures (Figure 1) they are supported via 2 points with 1 lateral plate incorporated in each cabinet and a special steel pin per side.

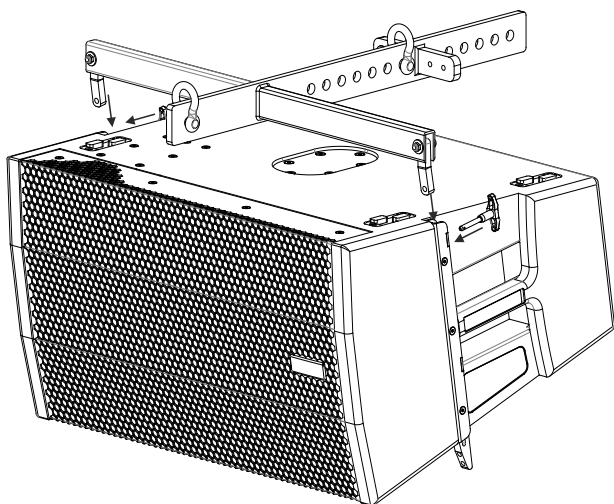

Figure 1

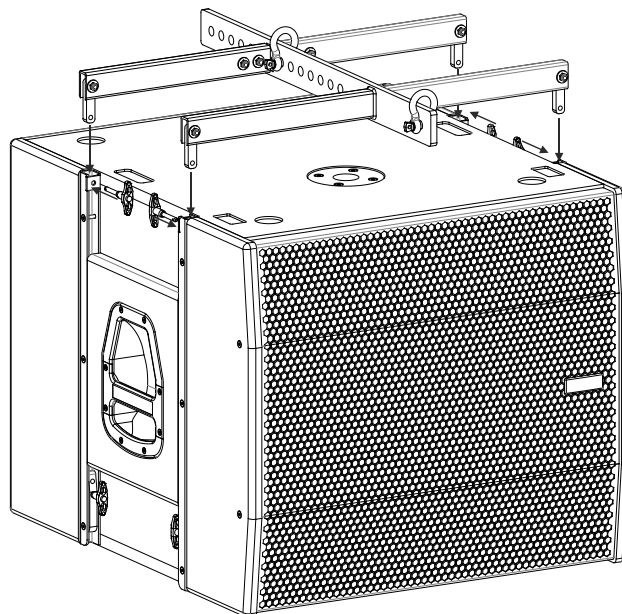
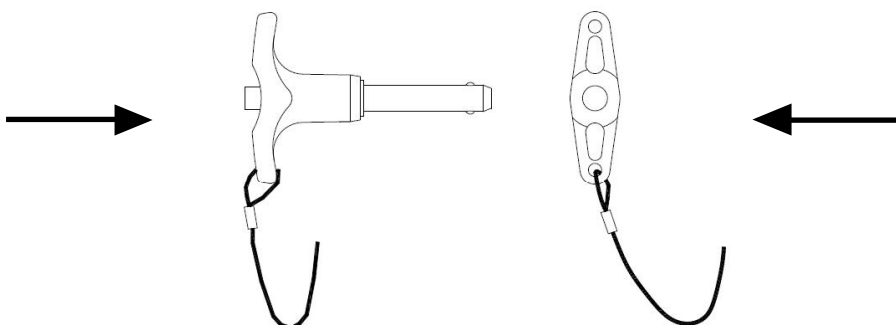

Figure 2

- When using the SV-CXA with the sub units (Figure 2) they are supported via 4 points with 2 lateral plates incorporated in each cabinet locked with two special steel pins per side.

The support of the cabinets to the flying system is carried out with special 6mm steel pins. To extract or fix the steel pins it is necessary to press the central button of the pin.



## HOW TO USE THE FLYING FRAME SV-CXA

- When using the flying frame with the CXA-18S sub units:

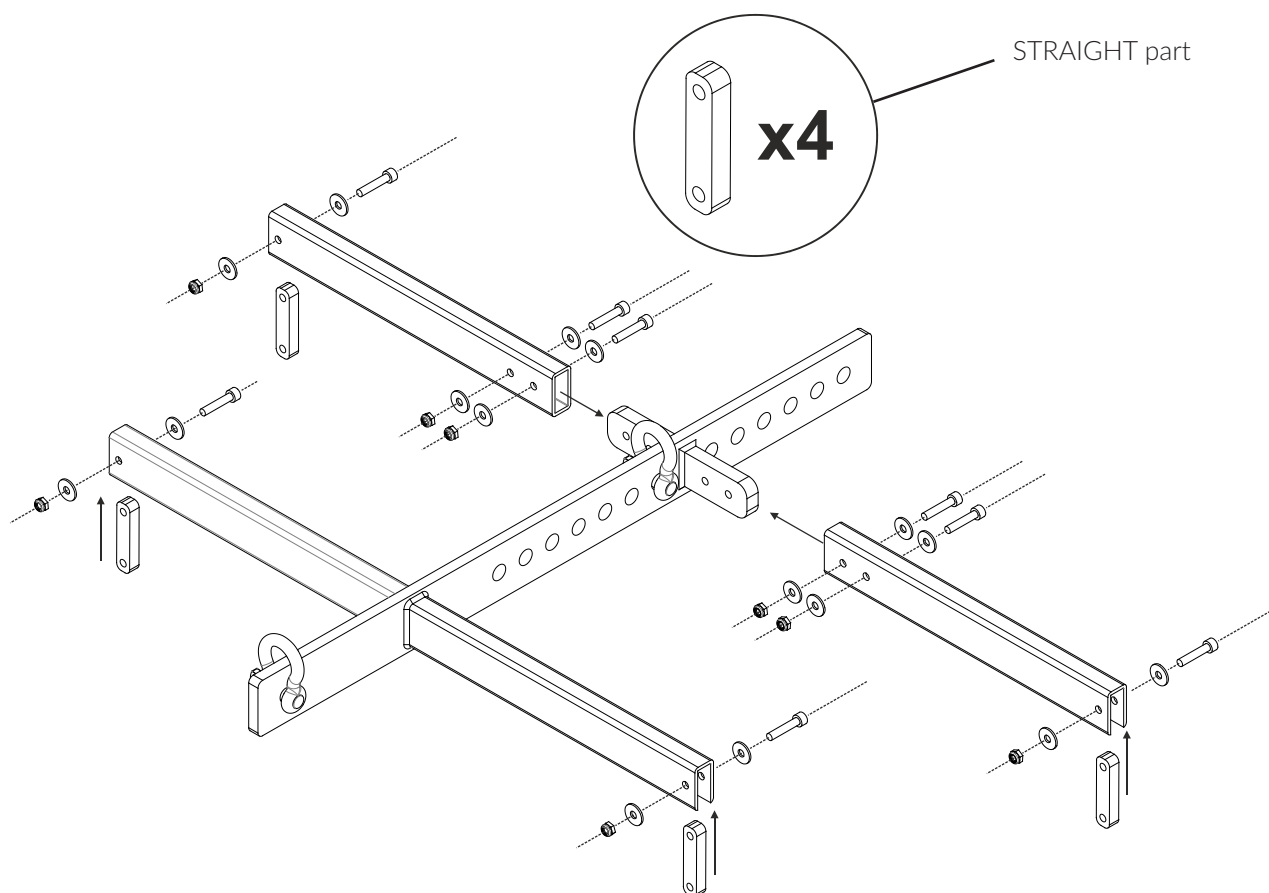

NOTE: Only use the four STRAIGHT parts provided



## ASSEMBLY OF THE FLYING FRAME SV-CXA

- When using the flying frame with the CXA-12 line array units:

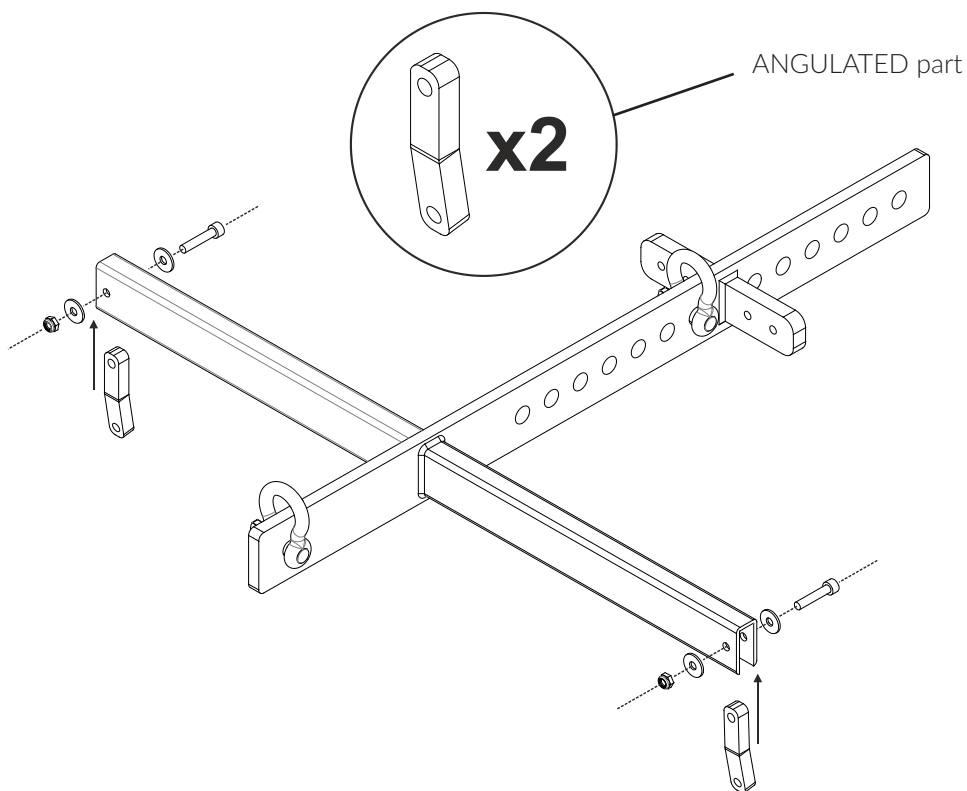

NOTE: Only use the two ANGULATED parts provided

## FITTING THE CABINETS TO SV-CXA

- Place the shackles in position so that when the system is lifted it raises correctly and achieves maximum system orientation. You have different holes in the frame to place these shackles and orientate the system to your requirements.

Fix the shackles to the elevation system (e.g motors, lifts) and elevate enough so as to fix the SV-CXA on to the first cabinet (CXA-12 or sub CXA-18S) so that the link of support, fit in to position in the upper lateral plates of the cabinet.

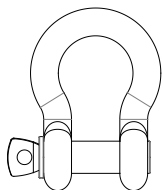

Note: To hang the system with motors or hoists, use the shackles code n° GS-12.

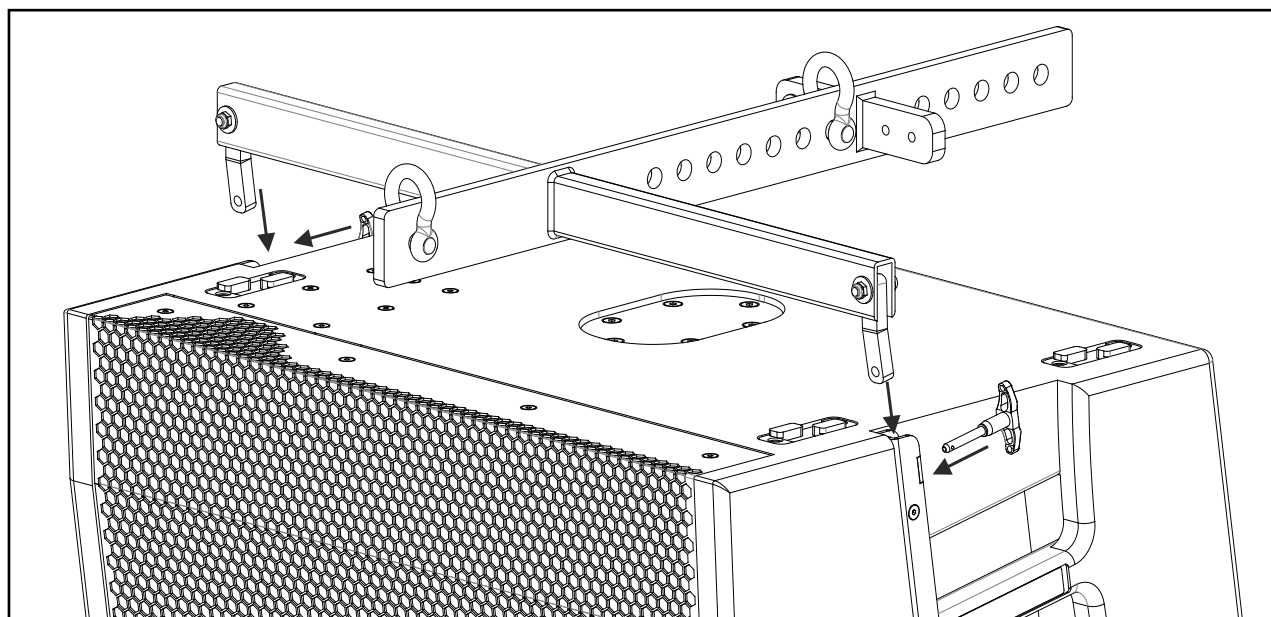
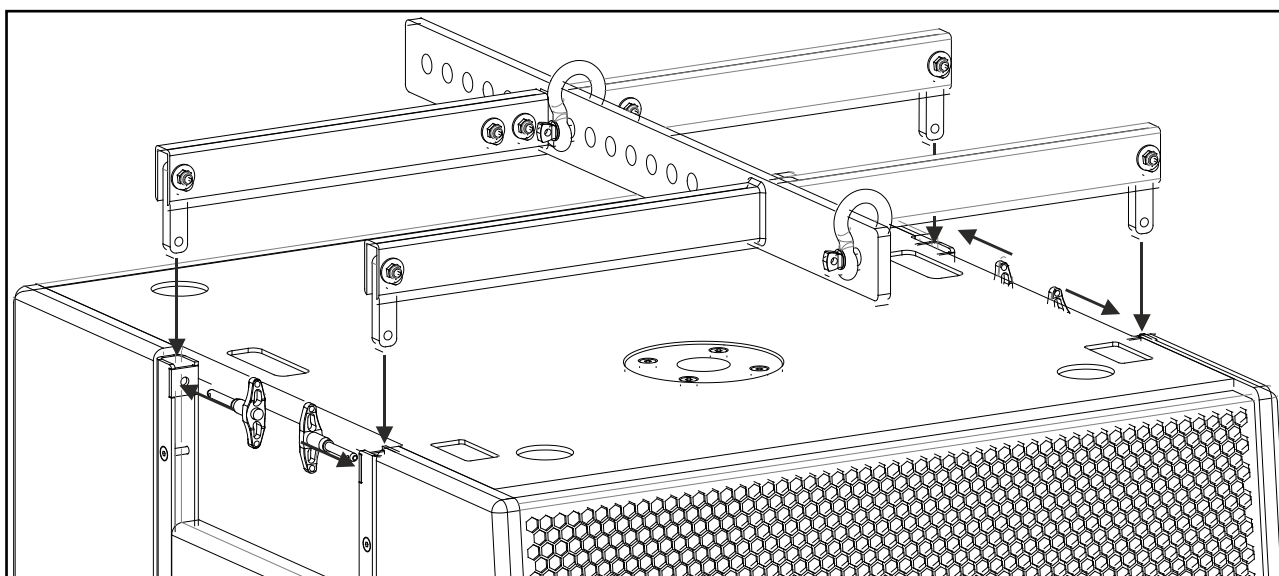

NOTE: Ensure all pins on all cabinets are inserted correctly and fully in their corresponding holes.

## FITTING THE CXA-12 CABINETS TO THE FLYING FRAME

- You can set up a CXA-12 array with a combination of a maximum of 4 cabinets and hanging the array with the flying frame SVA-CXA. Just follow these instructions.

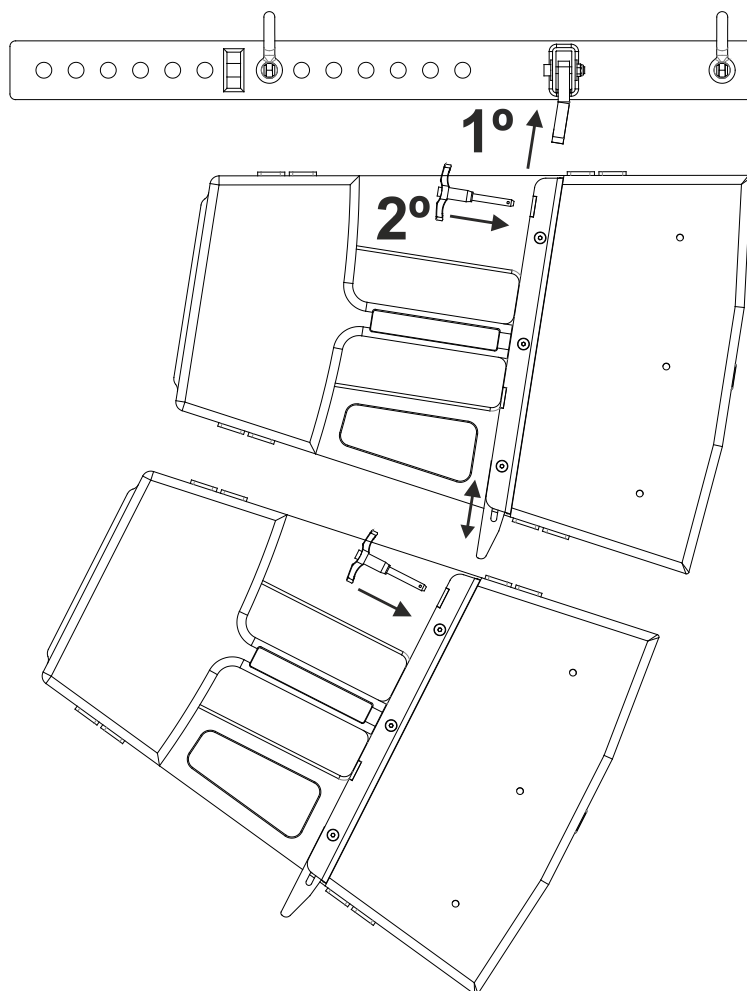

### Safety precautions

To fix the cabinets to the Flying Frame always use the pins supplied with the equipment. Do not use different bolts etc.

To hang the motors or manual hoists, use the hooks supplied with the flying frame SV-CXA. In case of failure, the link system used should be capable of supporting the total weight of the complete system.

If the system is installed outdoors check that the support structure will be stable against the wind strength and secure it with a cable to avoid pendular movement.

Do not stand underneath the system.

## FITTING THE CXA-18S CABINETS TO THE FLYING FRAME

- To fly the CXA-18S cabinets is very easy with the flying frame SVA-CXA. For a typical CXA array configuration you can fly a combination of a maximum 2 sub enclosures. The way to do it is very easy, just follow these 3 steps:

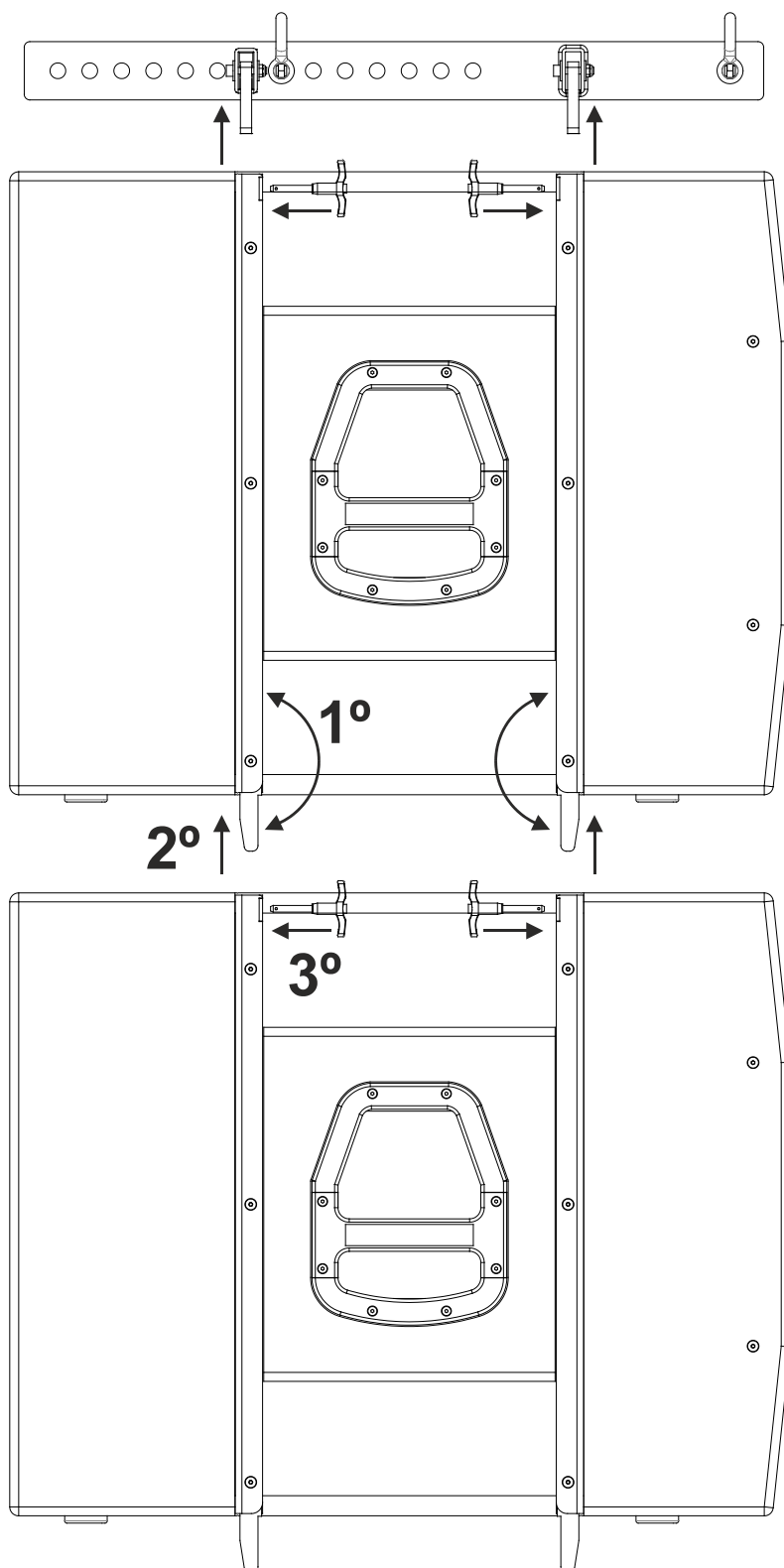

## FITTING CXA-12 WITH CXA-18S CABINETS

- To fly the CXA-18S cabinets is very easy with the flying frame SVA-CXA. For a typical CXA array configuration you can fly a combination of a maximum 2 sub enclosures. The way to do it is very easy, just follow these 3 steps:

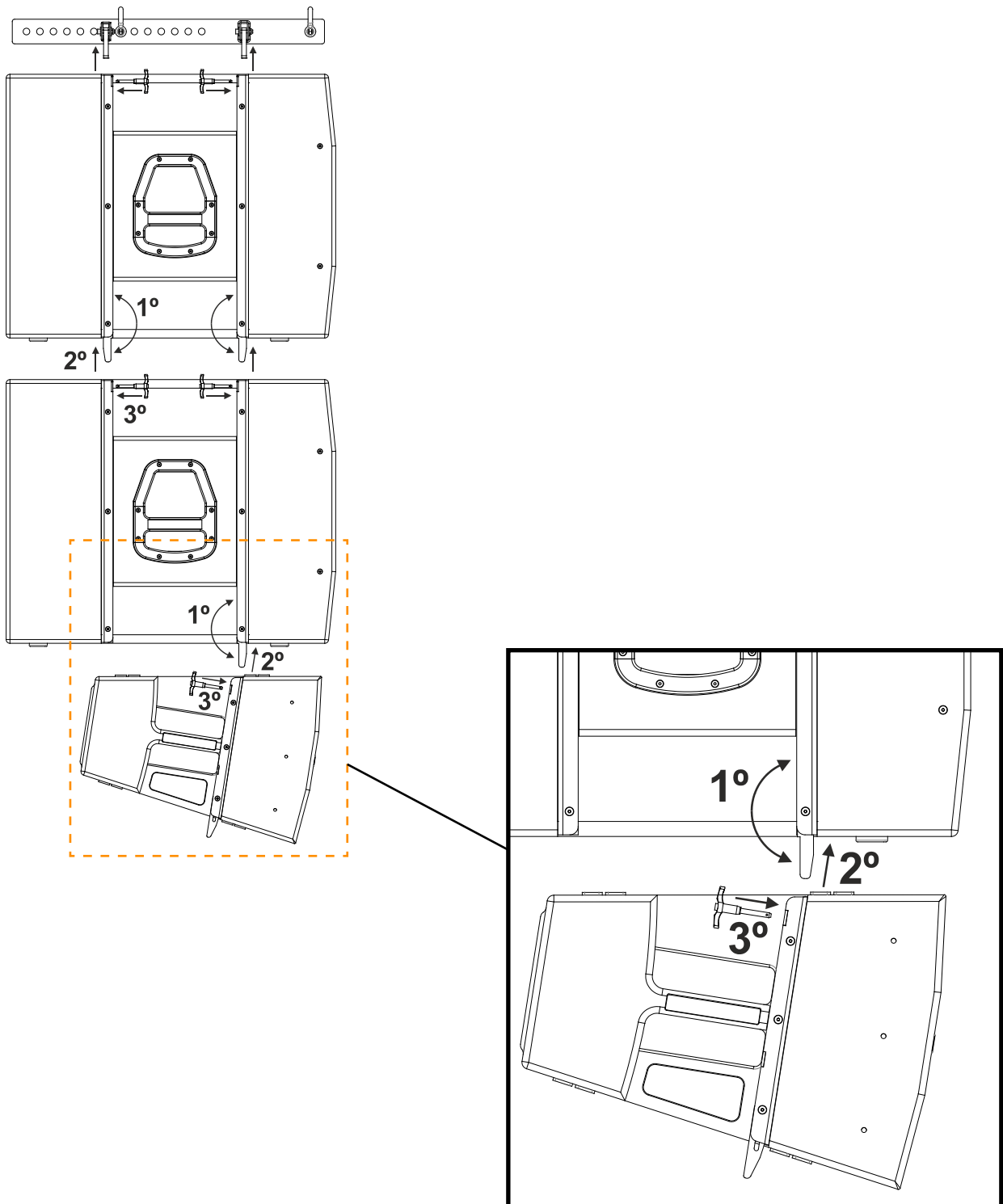

## THE CEILING BRACKET

- The UBR-CXA12 is a ceiling mounting system specially designed for CXA-12 cabinets. It is composed by the U type support made of steel, two lateral plates including 2 screws (DIN 7991 5x50) per plate and 4 fixing points (2 per side) to fix the U support to the cabinet.

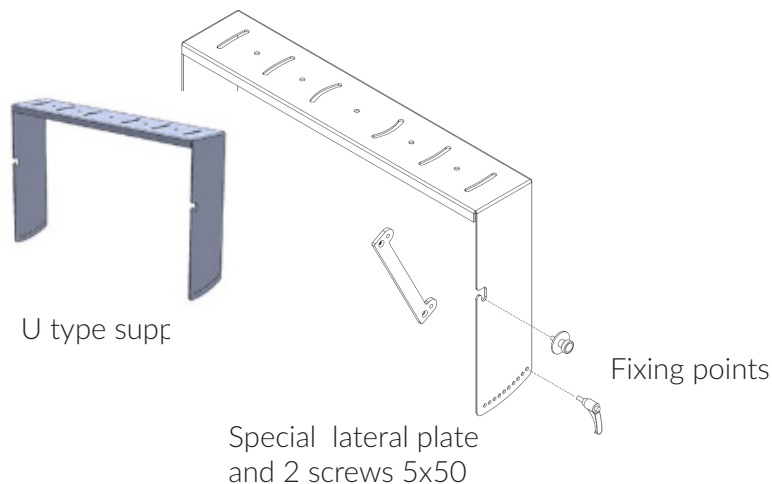

- How to use it?

First, fix the U type support in your ceiling. Then you have to mount a lateral plate in each side of the cabinet, where you will find 3 screws aligned.

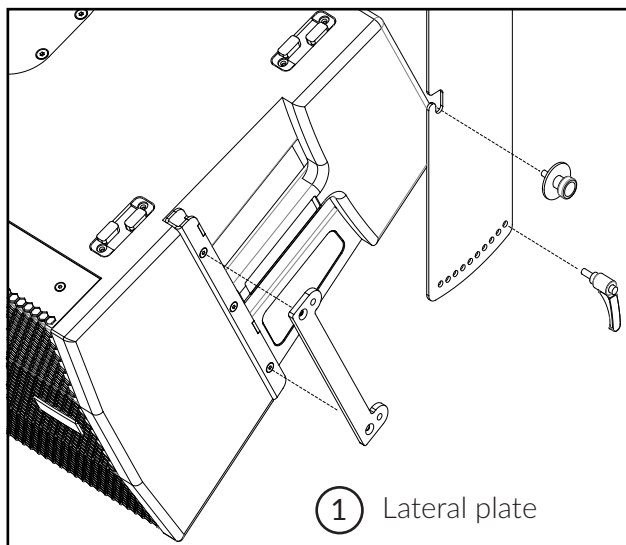

Just unscrew the upper and lower screws (don't touch the center screw) and retire these 2 screws from the cabinet. In their place you have to insert the screws DIN7991 5x50 (longer) provided with the UBR-CXA12 mounting kit.

You can fix the lateral plate using the new screws. Fix one plate in each side of the cabinet, in the position shown in the drawing.

Once the lateral plates are fixed you have to insert the knob into the upper hole of the plate. This will help you to connect the cabinet with the U type support.

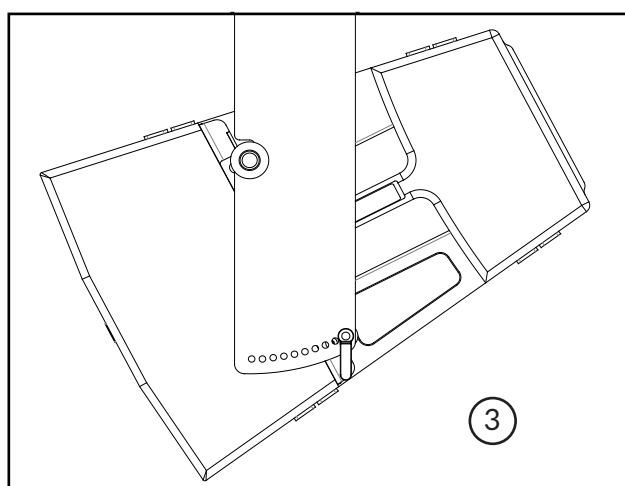
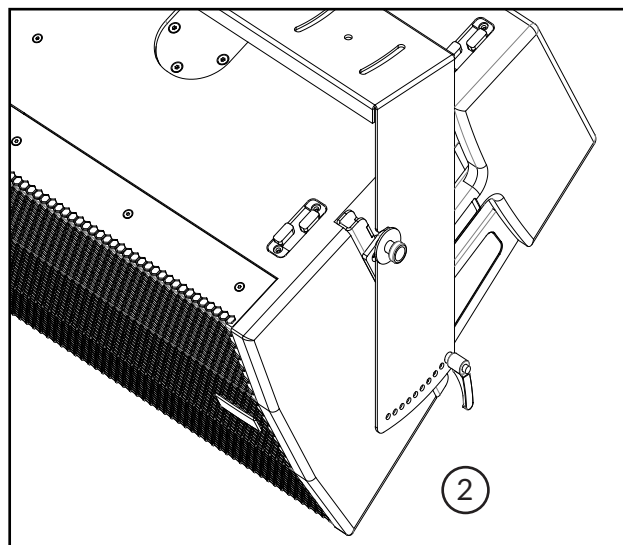

## CXA-12IN AND CXA-18IN CONFIGURATION

- The CXA-12IN and CXA-18IN cabinets are specially designed for installations. These cabinets can be flown with the flying frame SV-CXAIN.



CXA-12IN

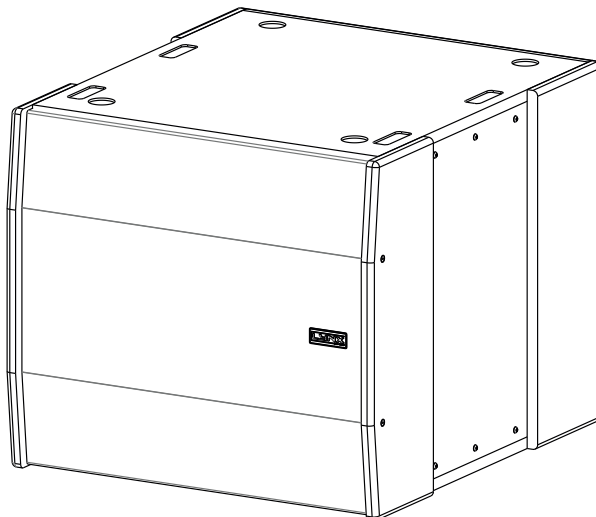

CXA-18IN

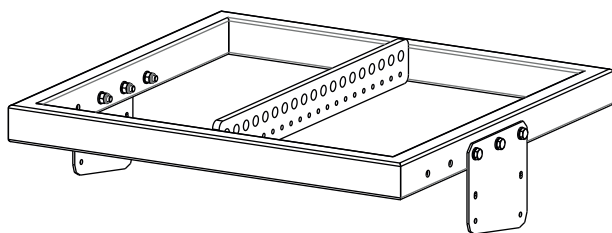

SV-CXAIN

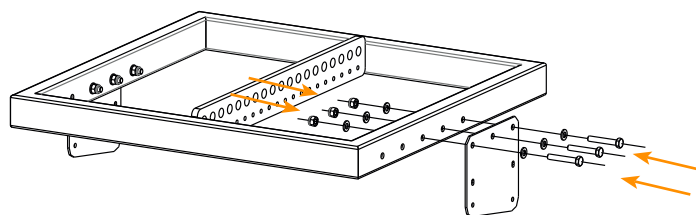

SV-CXAIN

- This is the flying frame for the CXA Install version.

- You can remove the screws and place them in any of the three positions available to change the array's inclination.

## CXA-IN FLOWN CONFIGURATION

- When you have the SV-CXAIN in the desired position, you can attach the CXA-18IN subwoofer or the CXA-12IN cabinet. Then you can add each cabinet with the matching screws.

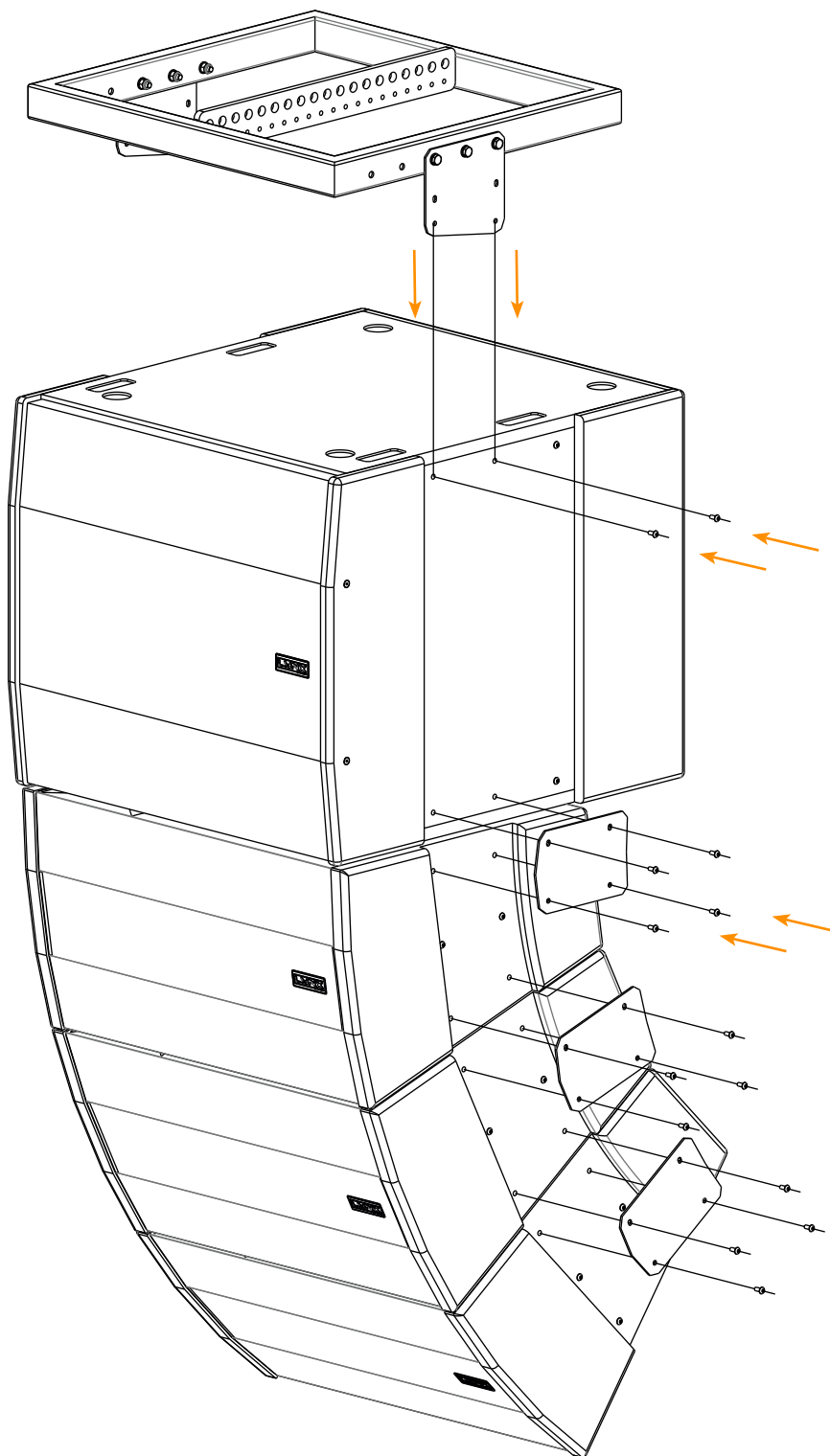



## ONLINE CONTROL SYSTEM

- Who is it for?

Users of Self powered DSP incorporated Lynx Pro Audio Cabinets where the user has requested the cabinets be supplied with the Ethernet Module kit.

- What is it for?

Obtain detailed information of cabinet behaviour and monitor the cabinet/s in real time. You can change the preset, gain, mute, polarity and phase. You can also activate the air absorption compensation and select the «SOLO» mode.

- How does it work?

Via Ethernet (cable or wireless). Once installed, the O.C.S. software automatically detects all the cabinets connected to the network and displays them in the O.C.S. window on the users PC.

- What does it show?

As well as displaying the cabinet model and IP address the O.C.S will be monitoring in real time and the user will be able to view RMS levels, Input clip, power module temperature, compression levels, air absorption compensation and cabinet angulation.

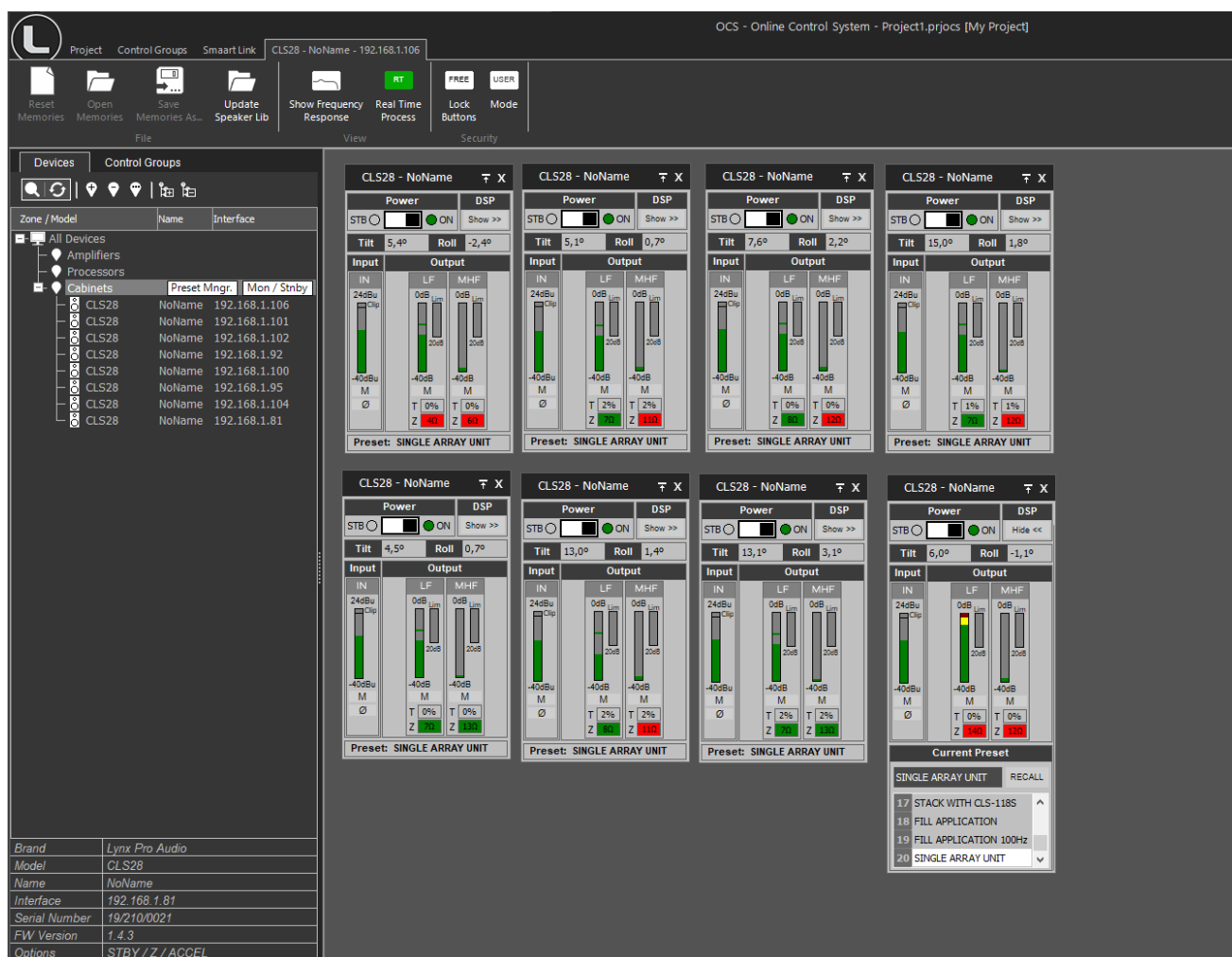

## HARDWARE AND ACCESSORIES

### RAINBOW 3D Acoustic Prediction Software

Lynx Pro Audio's R&D department is working on Rainbow 3D, a new acoustic simulation software with dynamic 3D features. With a sophisticated design, Rainbow 3D stands out for its speed, being able to provide a simulation in just a few seconds. It also provides algorithms for beam steering and optimizing the listening area.

- **Designed from scratch by professionals**

Rainbow 3D has been programmed from scratch by Lynx Pro Audio engineers, using new programming procedures that achieve an effective simulation with really low calculation time.

- **Multiple listening zones**

The program can simulate all Lynx Pro Audio's acoustic enclosures located in a 3D space, including the classic side, top and front views. It can also define multiple listening zones and allows offset positioning and symmetry. Blueprint images, textures and PNG format pictures can be imported.

- **Unlimited sound sources**

Allows the acoustic simulation for an unlimited number of sound sources and audio systems. You can place as many systems (subwoofers, line arrays, columns and individual boxes) as you desire. Also, the line arrays can be placed in stack or flown configuration.

- **Beam steering**

Rainbow 3D has the ability to add DSP processing to the simulation and uses algorithms to control the directivity (beam steering) in columns, without the need to tilt them physically, being able to divide the column into several beams that point to different zones.

- **Accurate optimization thanks to FIR filters**

Optimized algorithms are used in the listening area to improve the sound coverage and the frequency response. This feature can be executed in a matter of seconds. Additionally, the export of FIR coefficients can be performed with the optimization for later loading in the DSP via Ethernet or a USB device. In the near future direct communication with Lynx Pro Audio and OCS will be available.

- **Multiple measures and tools**

Likewise, the R&D department is developing multiple measurement and analysis tools for the calculated data. For example, the sound pressure curves (SPL) in the listening areas and the capture of virtual measurements that show the frequency response in the points of location indicated and added. Among other tools you will find autoplay and a wizard to set up different subwoofer arrangements.

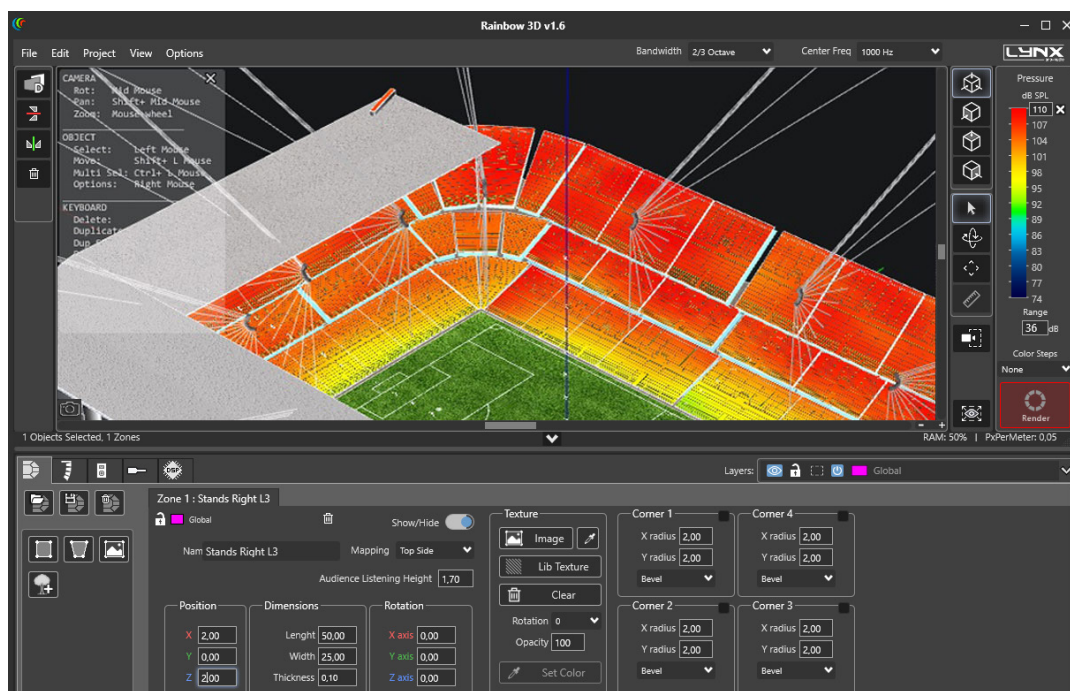

## HARDWARE AND ACCESSORIES

The CXA series include some accessories for installation and transport. The CXA-12 includes:



BALL-PSR6  
**Ball pin** with thread for CXA-12 and CXA-18S cabinets



SV-CXA  
**Flying frame** for the CXA-12 with a capacity for rigging of up to 6 cabinets



CB-CXA12  
**Ceiling Bracket** for CXA-12

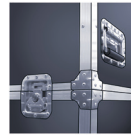

FC-3CXA12  
**Flight Case** to transport three CXA-12

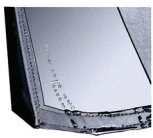

FD-1CXA12NL  
**Rain cover** for the back panel of the CXA-12



ST-CXA12  
**0° stack adaptor** for either the CXA-12 or the CXA-18S together with CXA-12

## About the rain hood

This rain hood is crafted to provide effective protection against regular rainfall. However, it is important to note that it is not engineered to serve as a waterproof barrier in extreme weather conditions. For severe storms or heavy downpours, we recommend additional protective gear to ensure complete waterproofing.



## DECLARATION OF CONFORMITY

**Lynx Pro Audio S.L.**  
Calle 1 - Pol. Ind. Picassent  
46220 Picassent (Valencia)  
SPAIN - EU  
Tel.: (+34) 961 10 96 01  
[www.lynxproaudio.com](http://www.lynxproaudio.com)

Lynx Pro Audio S.L. declares that CXA series are in conformity with the following EC directives:

Low Voltage Directive	2014/35/UE
Electromagnetic Compatibility EMC	2014/30/UE
RoHS Directive	2011/65/UE
RAEE (WEEE)	2012/19/UE

In accordance with Harmonized European Norms:

EN 60065:2014	Audio, video and similar electronic apparatus. Safety requirements
EN 55032:2012	Electromagnetic compatibility of multimedia equipment. Emission requeriments.
EN 55103-2:2009	Electromagnetic compatibility. Product family standard for audio, video, audiovisual and entertainment lighting control apparatus for professional use. Part 2: Immunity.
EN 50581:2012	Technical documentation for the assessment of electrical and electronic products with respect to the restriction of hazardous substances
CXA models:	CXA-12 / CXA-18S/ CXA-12IN / CXA-18IN



## LYNX PRO AUDIO GUARANTEE

Lynx products are guaranteed against every kind of manufacturing fault 3 year after the date of sale. When products are under guarantee, the repairing and the free supplying of the device parts in order to correct any kind of defect are guaranteed by Lynx Pro Audio S.L. In the case that the product could not be returned to the factory for checking and repairing, Lynx Pro Audio S.L. would supply all the necessary parts.

Lynx Pro Audio S.L. is not responsible for any damage or defect caused during the transport or caused by an undue or improper handling y a non-authorized person during the life of this guarantee.

All our products undergo rigorous tests and quality controls. We guarantee the characteristics described here within and their quality against any fabrication defect.

The user loses all warranty rights if he incorporates or carries out any modification to the product, if he uses it outside of the stated safe working loads or does not secure the system properly using all the pins in their corresponding holes.

For any question regarding the product, the user must quote the model and serial number.

**WEEE Declaration:** Electrical and electronic equipment must be disposed of separately from normal waste at the end of its operational lifetime. Please dispose of this product according to the respective national regulations or contractual agreements. If there are any further questions concerning the disposal of this product please contact Lynx Pro Audio S.L.