

ADP-212M



DATA SHEET

pag.1/3 V.13.03

- ▶ Class D Powered (bi-amplified)
- ▶ Integrated Digital Processing
- ▶ Internal temperature control
- ▶ Electronic protection
- ▶ FIR linear phase filtering
- ▶ Online control available



APPLICATION:

- Reinforcement
- Stage monitor
- Portable installation
- Voice reinforcement

GENERAL DESCRIPTION:

The ADP-212M Stage monitor is part of the ADP Self powered, DSP (with FIR Filters) integrated Series. It has been designed to offer the utmost sound reinforcement reliability, incorporating the latest acoustical and electrical technology and delivering incredible, dynamic sound.

two-way stage monitor providing exceptional performance. For the low-mid frequencies it uses two 12" (76mm voice coil) transducers. The high frequencies are looked after by a neodymium compression driver with a 1.4" titanium diaphragm delivering 55° conic dispersion.

The ADP-212M is powered with a total of 2250W of class D amplification with PFC (Power Factor Correction), 1500W for the low/mid frequencies and 750W for the high frequencies. Each cabinet has a DSP integrated for system protection and optimization. Other features include temperature sensor, fan speed control, Ethernet options and many more.

Weight and performance are two important considerations when choosing a monitor. The ADP-212M has an unbeatable power to size ratio, there is no need for external amplification racks, is very light weight and as such is the ideal solution for portable or fixed sound reinforcement enabling quick and easy set-ups.

SPECIFICATIONS:

FREQUENCY RANGE	55Hz -20KHz
FREQUENCY RESPONSE	60Hz- 18KHz ± 3dB
HORIZONTAL COVERAGE	55°
VERTICAL COVERAGE	55°
MAX SPL	136 dB/ 139dB peak
CROSSOVER	1400 Hz
<hr/>	
TRANSDUCERS	LF/MF: 2 x 12" HF: 1.4" Titanium diaphragm
SHAPE	Trapezoidal
POWER AMPLIFIER	2250W Class D with Switching Power supply power factor correction PFC technology 2 power modules 1500W Low/Mid + 750W High
DSP	Internal processor DSPB-22® with FIR filters
CABINET ADJUSTMENT	Side panel LCD screen
INTERNAL CONTROLS	Temperature sensor / Fan Speed control
SIGNAL CONNECTION	NEUTRIK connectors XLR Male Input XLR Female Loop Thru
CONTROL CONNECTIONS	USB (DSP programming), ETHERNET* (Online Control System OCS)
AC POWER	85v / 270v selectable. 50/60 Hz 3A
AC CONNECTIONS	16A NEUTRIK POWERCON Looping Output
CONSTRUCTION	15 mm Premium Birch plywood
FINISH	High resistant water-based black paint
FRONT DESIGN	Black antirust steel grille and foam protector
<hr/>	
DIMENSIONS (H x W x D)	445 x 688 x 655 mm
WEIGHT	42 Kg (92 lbs)

* Ethernet connection is optional.

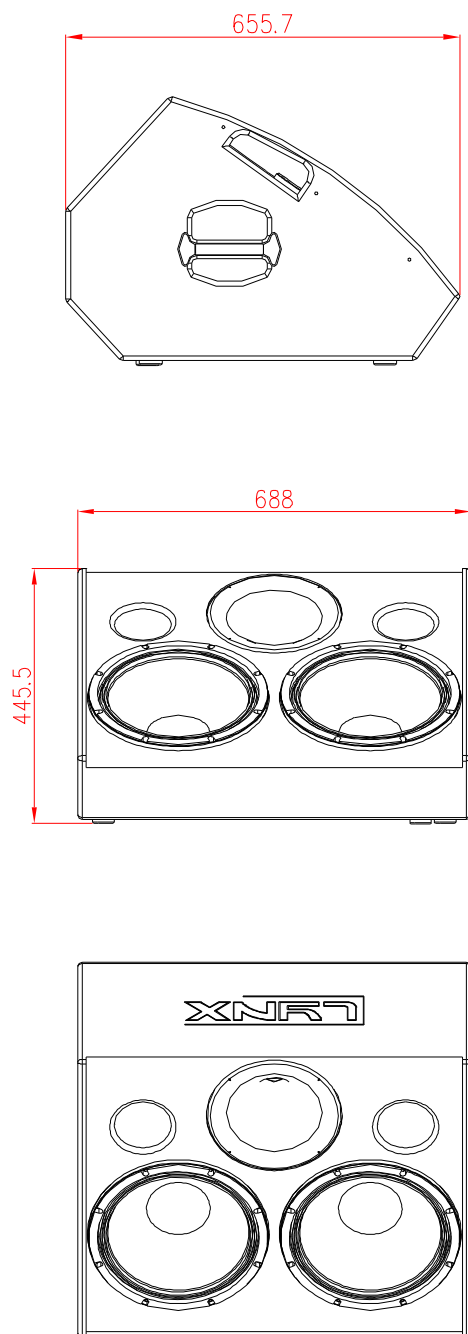

Dimensions in mm.

KEY FEATURES AND BENEFITS:

- **SELF POWERED:** Bi-amplified Class D with switching power supply and PFC (Power Factor Correction). With PFC the power supply regulates itself when AC mains change, so the amp power output will not change with mains swinging. This system is also very environmentally friendly with a reduction of approximately 40% of current draw.. Includes one 1500W power module for the LF/MF and a 750W for the HF. The amplification far exceeds the transducers needs thus resulting in high output, high damping factor and extremely low levels of distortion. The module is also equipped with extensive protection circuitry including power limiters, thermal shutdown, short circuit & overload and clip limiter.

- **DIGITAL PROCESSING & DOUBLE DYNAMICS:** Latest generation 24bit/96Khz digital processor which optimizes the system components. It includes 2 channel processing electronics with functions for phase correction, driver protection, gain control, equalization and crossover, using double precision filters with 56bit internal processing. This enables a noticeable reduction in distortion with clean and clear equalization. The DSP incorporates sophisticated double protection limitation; RMS and Peak. The RMS limiter is used to adjust the transducer reproduction level, maintaining the original dynamics whilst at the same time respecting the original transients and achieving a better acoustical result. The Peak limiter controls the movement of the speaker, protecting it from any damage and also reducing distortion caused by over-excitation. These double dynamics lower levels of distortion and provide protection for all the speaker components and internal electronics.

- **FIR FILTERS:** Linear phase technology, using FIR (Finite Impulse Response) filters, achieving better transition area between all the cabinet's components, better temporary system alignment and greater impulse response. All this resulting in a much improved sound and phase response enabling the user to optimize their systems when using different sources of sound.

- **TEMPERATURE & PROTECTION CONTROL:** Via internal sensors a micro controller analyzes in real time the temperature of each power module. It then automatically adjusts the fan speed to apply the correct temperature dissipation, reducing both the speed of the fan and the noise generated leaving the system as quiet as possible.

- **LCD SCREEN:** Located on the cabinet's back panel the LCD shows information such as the preset name, gain level and temperature and enables the user to select between presets.

- **COMPONENTS:** Dual 12" exponential speakers with aluminium voice coil. Titanium diaphragm for the HF driver with Mylar surround to provide damping and avoid resonant peaks typical of metal surrounds. Extremely smooth and extended high frequency response. Special GFK horn (55° x 55°) for improved acoustic loading and controlled coverage.

- **HARDWARE:** Cabinet constructed from premium birch plywood and finished with high-resistant water based black paint.

SOFTWARE:



- ONLINE CONTROL SYSTEM

Offers detailed system information for each cabinet and via ethernet or PC controls the cabinet/s in real time.



- RAINBOW

Acoustical Prediction software for accurate loudspeaker planning offering both horizontal and vertical views.

ADP-212M



DATA SHEET

pag.3/3 V.13.03

FREQUENCY / PHASE RESPONSE

