

LX-212S



DATA SHEET

pag.1/2 V.06.17

- ▶ Class D Powered (bi-amplified)
- ▶ Integrated Digital Processing
- ▶ Internal temperature control
- ▶ Electronic protection
- ▶ High quality components
- ▶ Online control available



APPLICATIONS:

- Theatres
- Concert Halls
- Auditoriums
- Houses of worship
- Conferences
- Sport Stadiums
- Outdoor events

GENERAL DESCRIPTION:

The LX-212S is part of the LX Line Array Series and is the ideal solution for application in theatres, concert halls, stadiums, auditoriums, conference halls or any event where high precision Line Array is required. This sub-bass cabinet is the ideal combination where low frequency reinforcement is required for the LX-V8 or LX-F6.

High power sub-bass cabinet with two 12" (4" DUO double inner/outer voice coil winding) low frequency neodymium transducers with helicex cooling technology in bass reflex, direct radiation configuration. This cabinet delivers high sensitivity with massive mechanical displacement capability.

The system is powered with a total of 2000W of class D amplification and each cabinet has its own DSP integrated. Other features include temperature sensor, Ethernet options and more.

The LX-212S is recommended to add sub-bass reinforcement for either the LX-F6 or the LX-V8.

SPECIFICATIONS:

FREQUENCY RANGE	25Hz -300Hz
FREQUENCY RESPONSE	35Hz- 250Hz ± 3dB
HORIZONTAL COVERAGE	360° single unit
MAX SPL	136 dB/ 139dB peak
TRANSDUCERS	LF: 2 x 12" 100 mm Voice Coil 8 Ohm
SHAPE	Bass reflex direct radiation
POWER AMPLIFIER	2000W Class D with Switching Power supply 2 x 1000W
DSP	Internal LYNX digital processor DSPB-44®
CABINET ADJUSTMENT	Back panel LCD screen
INTERNAL CONTROLS	Temperature sensor / Fan Speed
SIGNAL CONNECTION	NEUTRIK connectors XLR Male Input XLR Female Loop Thru
CONTROL CONNECTIONS	USB (DSP programming), ETHERNET* (Online Control System OCS®)
AC POWER	230V / 115V selectable 50/60 Hz 3A
AC CONNECTIONS	16A NEUTRIK POWERCON with Looping Output
CONSTRUCTION	18 mm Premium birch plywood
FINISH	High resistant water-based black paint (white RAL)
FRONT DESIGN	Antirush Black metal grille
DIMENSIONS (H x W x D)	522 x 646 x 525 mm
WEIGHT	58 Kg (128 lbs)
RIGGING	Integrated flying plates

LX-212S



DATA SHEET

pag.2/2 V.06.17

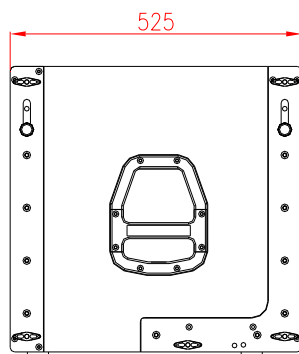
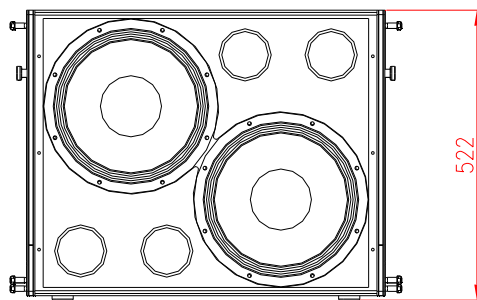
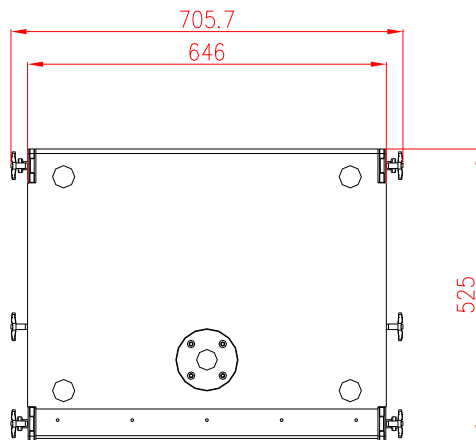

Dimensions in mm.

SOFTWARE:



- ONLINE CONTROL SYSTEM

Offers detailed system information for each cabinet and via ethernet or PC controls the cabinet/s in real time.



- RAINBOW

Acoustical Prediction software for accurate loudspeaker planning offering both horizontal and vertical views.

KEY FEATURES:

SELF POWERED

Bi-amplified Class D with switching power supply. Includes two 1000W power modules, one for each 12" transducer. The amplification far exceeds the transducers needs thus resulting in high output, high damping factor and extremely low levels of distortion.

DIGITAL PROCESSING & DOUBLE DYNAMICS

Latest generation 24bit/96Khz digital processor which optimizes the system components. It includes 2 channel processing electronics with functions for phase correction, driver protection, gain control, equalization and crossover, using double precision filters with 56bit internal processing. This enables a noticeable reduction in distortion with clean and clear equalization. The DSP incorporates sophisticated double protection limitation; RMS and Peak. The RMS limiter is used to adjust the transducer reproduction level, maintaining the original dynamics whilst at the same time respecting the original transients and achieving a better acoustical result. The Peak limiter controls the movement of the speaker, protecting it from any damage and also reducing distortion caused by over-excursion. These double dynamics lower levels of distortion and provide protection for all the speaker components and internal electronics.

TEMPERATURE & PROTECTION CONTROL

Via internal sensors a micro controller analyzes in real time the temperature of each power module.

COMPONENTS

Low frequency neodymium transducers with HELICEX cooling technology, MMSS technology and 4" DUO double inner/outer voice coil. Weather protected membrane for outdoor use.

HARDWARE

Cabinet constructed from premium birch plywood and finished with high-resistant water based black paint. Robust steel flying frame for easy rigging options and arrayable with LX-F6 cabinets.

HARDWARE:



SV-LX215S
Flying frame

SP-TLF6
T-Bar for LX-F6
on LX-212S



TL-A220
PA lift



PR-01
Flying frame angle adjust



SA-LX215
To stack LX-F6 on LX-212S