

GXR-15

USER MANUAL

GXR series

V.16.04

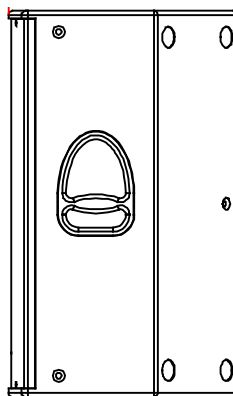

Lynx Pro Audio S.L.

Valencia, Spain - www.lynxproaudio.com - info@lynxproaudio.com

GXR-15



Manufacturer



LYNX Pro Audio S.L.
Calle 1 - Pol. Ind. Picassent
E-46220 Picassent (Valencia)



CE CERTIFICATION, EUROPEAN PRODUCT

CONTENTS

- SAFETY PRECAUTIONS	4
- SYSTEM OVERVIEW	
GXR-15	5
BACK PANEL	6
CONNECTORS AND CONNECTIONS	6
- CONFIGURING THE DIGITAL SIGNAL PROCESSOR	
CONFIGURING THE DSP OPTIONS	8
CONFIGURATION PANEL	8
SELECT THE INPUT	9
SELECT AND RUN PRESET	9
- ONLINE CONTROL SYSTEM	10
- CERTIFICATIONS AND GUARANTEE	11

Before starting to use this device, please read this instruction manual carefully. Keep these instructions in the place where the equipment will be used and with easy access to them.

- Electrical appliance.



The exclamation mark within a triangle identifies the presence of electricity. Use the system carefully without wet hands or feet. Avoid installing the speaker in wet or excessively humid places. Do not place material that contains liquid on or near the unit. Avoid dripping or splashing water or any liquid over the unit. Regularly check the condition of the cables and make sure these are not being walked on or pinched. Connect the speaker to bipolar, earthed mains. The mains plug must be connected to the appropriate protection (fuse or breaker). Connection to any other type of mains could result in an electrical shock and violate local electrical codes. **CAUTION: DO NOT CONNECT OR DISCONNECT THE AC POWER CONNECTORS UNDER LOAD.**

- Heavy equipment.



Apply back protection when using the system. Avoid loading and unloading at heights.

- Electrical shock risk.



The diagonal mark within a triangle identifies the presence of dangerous voltage. Do not open or handle the interior of the box. These parts are not to be adjusted by the user. For maintenance and/or repair please go to an authorized service centre. In order to reduce the risk of electric shock, disconnect from AC before plug in or unplugging Audio signal cables. Reconnect to AC only if all signal connections are made and secured. Never manipulate the ground type plug provided. The AC mains plugs should always remain accessible for operation. Unplug the loudspeaker during storms or when it's being used for a long time.

- Hearing damage risk.



These systems can reproduce large quantities of sound pressure which can damage hearing. Take precautions if you are going to be near them for extended amounts of time and do not get too close.

- Hanging – Flying.



Do not hang the cabinets from the handles or from any other part other than the designated hanging point. When flying this system please observe the technical and “Rainbow” software data carefully. Never exceed the maximum safe working loads or ignore the instructions included within this manual. Use Only flying accessories provided by Lynx Pro Audio S.L. Rigging must be always carried out by professionals.

- Delicate Material.



Please ensure no foreign object or water enters the speaker. Only clean the unit with dry cloths. Do not use solvents.

-Overheating – Fire risk.



To reduce the risk of the speaker over heating, avoid direct contact with sunlight. Avoid placing the unit close to heat inducing objects such as radiators. Do not cover the equipment in use and do not block any ventilation openings. Do not put naked flame, such as lighted candles, close or on top of the unit.

- Electromagnetic and interferente emissions.



Avoid placing objects which through electromagnetic waves can damage the unit, such as mobile phones, lap tops, magnetic strip cards etc.

This system complies with normatives

EN 55103-1 (1)

EN 55103-2 (2)

(1) This device may not cause harmful interferences.

(2) This device may receive interference including interferences that may cause undesired working.

-IMPORTANT NOTE.



This Equipment must be used in accordance with these instructions and by trained professional personnel only. This equipment should not be used in places with extreme tropical climates. Don't

CABINET OVERVIEW

GXR-15

Components	LF: 15" 2,5" voice coil, Malt Cross Cooling System	Processing	96 KHz / 64 bit double precision DSP with FIR filters
	HF: 1" Exit compression Driver , 1,7" aluminium voice coil	Control	User control interface with LCD
Frequency Range	60Hz – 20 KHz (-10dB)	Control Connections	USB (DSP programming)
Frequency Response	66Hz – 18 KHz (± 3dB)	AC Power	90 – 264V. 50/60 Hz with PFC
Max. SPL	128 dB	AC Connections	16A Neutrik powerCon TRUE1 with looping output
Coverage angle	90° x 40° constant directivity horn. Rotatable	Finish	High resistant water-based black paint
Power	1400 W Class D with switching power supply & PFC	Material	15 mm Premium birch plywood
LF Amplifier	1 x 800 W	Dimensions (H x W x D)	730 x 444 x 433 mm
HF Amplifier	1 x 600 W	Weight	28,5 Kg (62.8 lbs)

Ethernet connection is optional.

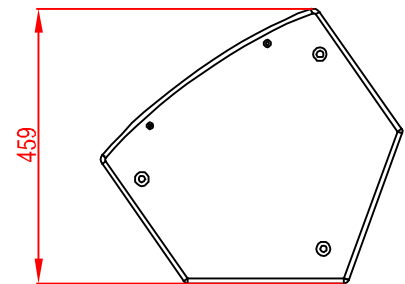
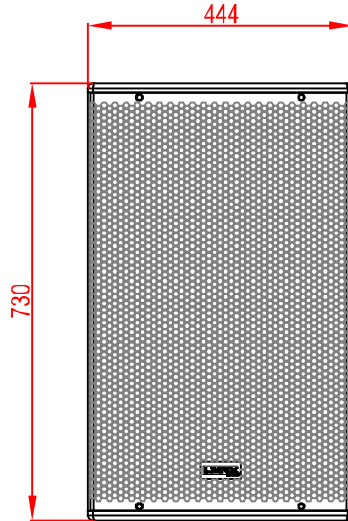
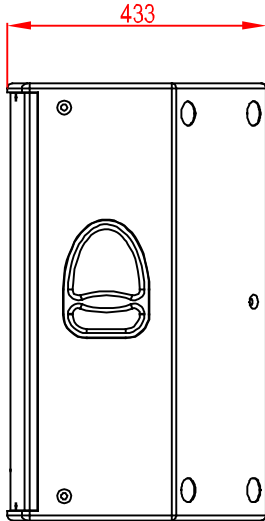

Dimensions in mm

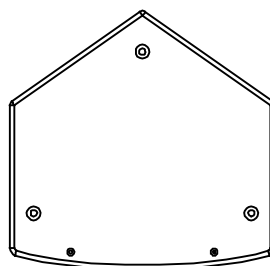

GXR BACK PANEL

The rear panel includes the connectors and digital control display.

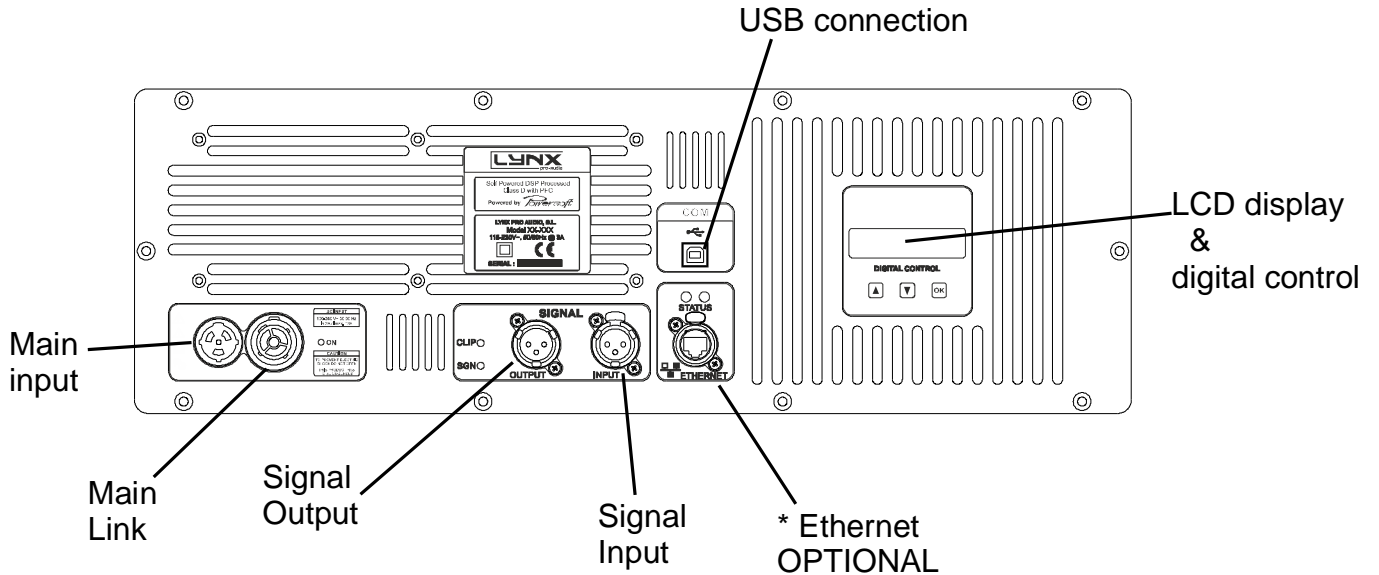

* Available when the user has requested the cabinets to be supplied with the Ethernet Module kit.

CONNECTORS AND CONNECTIONS

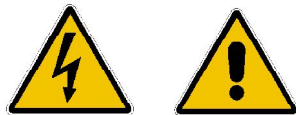

CAUTION: Do not connect or disconnect the AC Power connectors under load.

SOCKET POWERCON TRUE1

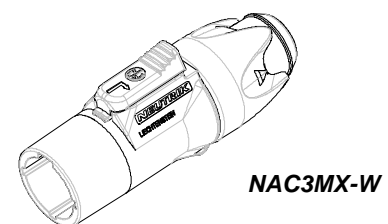
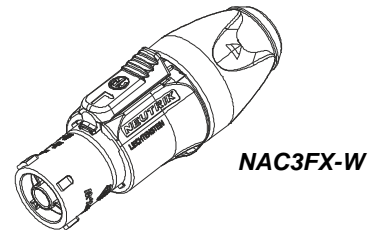
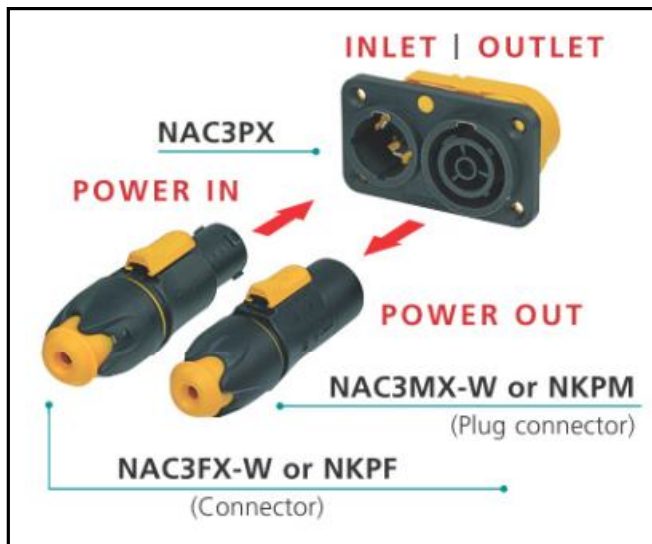
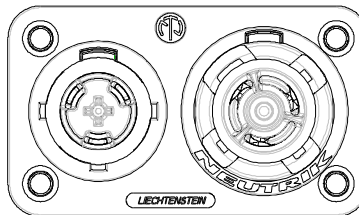

CONNECTORS AND CONNECTIONS

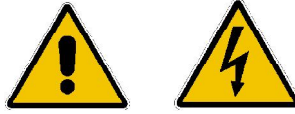

XLR SOCKET CONNECTORS

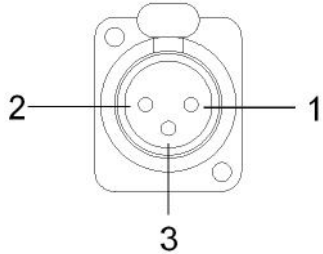

INPUTS
1.- EARTH
2.- LIVE (+)
3.- LIVE (-)

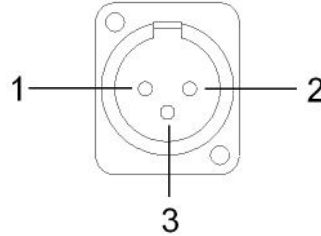

OUTPUTS
1.- EARTH
2.- LIVE (+)
3.- LIVE (-)

XLR AERIAL CONNECTORS

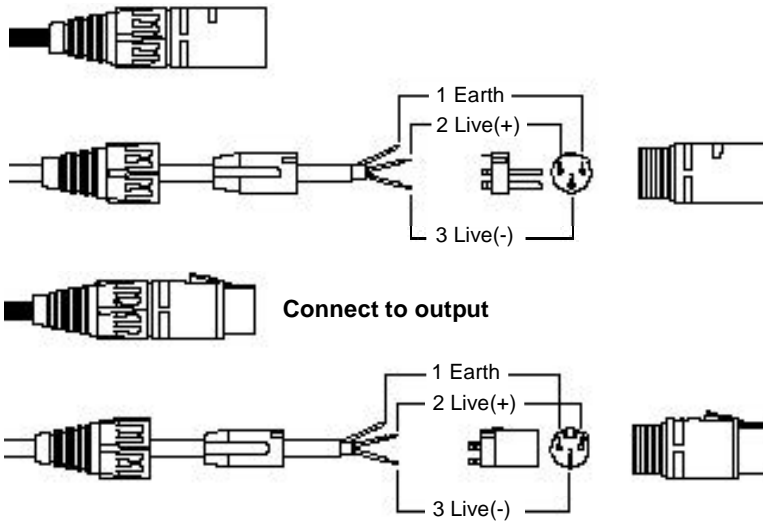

FIR FILTERS

Finite Impulse Response (FIR) filters are used in the signal processing of the GXR-15 cabinet. FIR is a type of digital filter with linear phase characteristics. This frees system designers from the constraints of phase anomalies associated with analogue filters or their digital versions (IIR, Infinite Impulse Response). When properly used, FIR filtering can audibly improve a system's impulse response and reduce crossover interference.

CONFIGURING THE CABINET DSP OPTIONS

From the buttons below the display on the cabinet's back panel you are able to configure the Basic adjustment functions of the internal DSP.

Please note that you must apply the desired configuration in each one cabinet and requires electrical power to work.

CONFIGURATION PANEL

On the back panel you will see 3 buttons and an information screen, on which you can read the established parameters and information such as amplification module temperature, input signal level and name of the current preset (Fig1). If changes are not made the display will automatically dim to save energy and avoid unnecessary light in situations where light is not wanted. To re-activate the light simply press the OK button.



Fig 1

SELECT THE INPUT: DIGITAL OR ANALOG

This selection is only available when the user has requested the cabinets to be supplied with the Digital input kit. There are four input options: Analog / Digital L / Digital R / Digital L+R

To select the input mode just press the OK button (3) and the up button (1), both at the same time but pressing the OK button first. Then you can select one of the four options using the up button (1).

To confirm your selection press OK (3) until the progress bar finishes.

The display will show an inverted D (digital) or an inverted A (analog) so you can always know if the input is digital or analog.

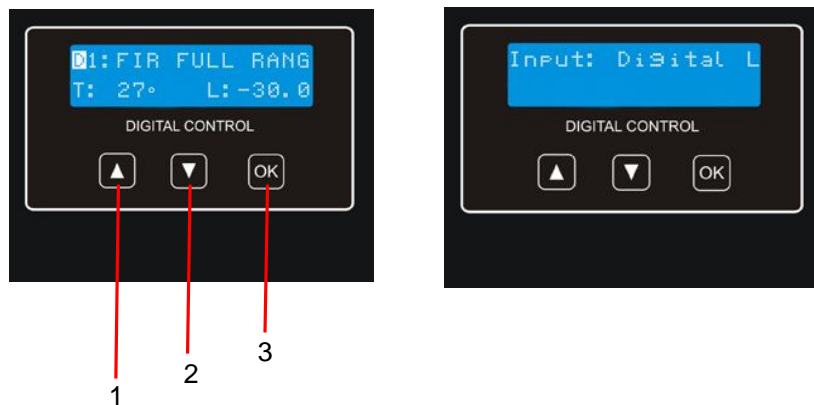

SELECT AND RUN PRESET

To change the preset configuration (see Fig 2) just press the up button (1) and down button (2) until you see the title and present number required and once found press OK (3) until the progress bar finishes (Fig 3). The display will indicate “Loading DSP” (Fig 4)



Fig 2



Fig 3



Fig 4

Note: In case of a power cut, the DSP will save its last configuration when restarted.

ONLINE CONTROL SYSTEM

Who is it for?

Users of Self powered DSP incorporated Lynx Pro Audio Cabinets where the user has requested the cabinets be supplied with the Ethernet Module kit.

What is it for?

Obtain detailed information of cabinet behaviour and monitor the cabinet/s in real time. You can change the preset, gain, mute, polarity and phase. You can also activate the air absorption compensation and select the «SOLO» mode.

How does it work?

Via Ethernet (cable or wireless). Once installed, the O.C.S. software automatically detects all the cabinets connected to the network and displays them in the O.C.S. window on the users PC.

What does it show?

As well as displaying the cabinet model and IP address the O.C.S will be monitoring in real time and the user will be able to view RMS levels, Input clip, power module temperature, compression levels, air absorption compensation and cabinet angulation.

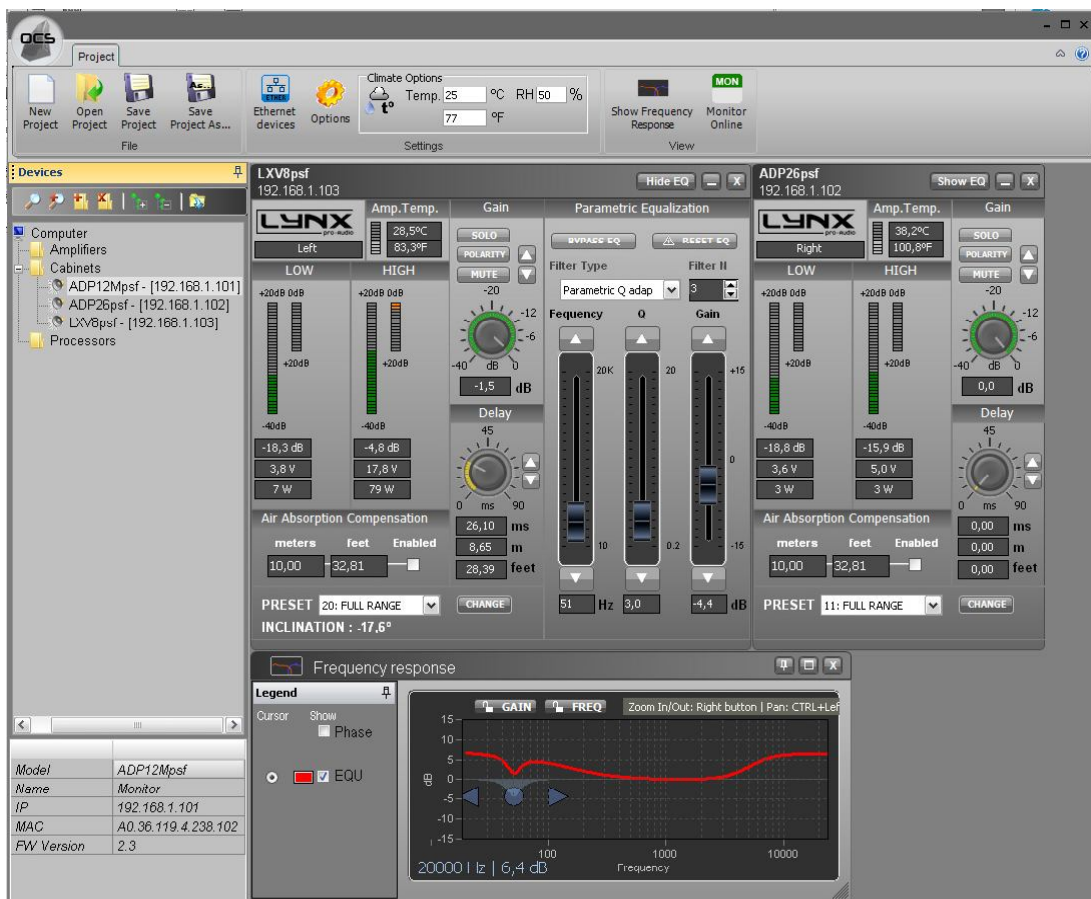

**DECLARATION OF CONFORMITY**

LYNX Pro Audio S.L.
Calle 7 - Pol. Ind. Picassent
E-46220 Picassent (Valencia)

Lynx Pro Audio S.L. declares that GR series are in conformity with the following EC directives:

Low Voltage Directive	2006/95/EC
Electromagnetic Compatibility EMC	2004/108/EC
RoHS Directive	2002/95/EC

In accordance with Harmonized European Norms:

EN 60065:2002	Audio, video and similar electronic apparatus. Safety requirements
EN 55103-1:1996	Electromagnetic compatibility. Product family standard for audio, video, audiovisual and entertainment lighting control apparatus for professional use. Part 1: Emission.
EN 55103-2:1996	Electromagnetic compatibility. Product family standard for audio, video, audiovisual and entertainment lighting control apparatus for professional use. Part 2: Immunity.
GR series models:	GXR-215 / GXR-18S / GXR-15 / GXR-12

WEEE Declaration: Electrical and electronic equipment must be disposed of separately from normal waste at the end of its operational lifetime. Please dispose of this product according to the respective national regulations or contractual agreements. If there are any further questions concerning the disposal of this product please contact Lynx Pro Audio S.L.

LYNX PRO AUDIO GUARANTEE

Lynx products are guaranteed against every kind of manufacturing fault 2 year after the date of sale. When products are under guarantee, the repairing and the free supplying of the device parts in order to correct any kind of defect are guaranteed by Lynx Pro Audio S.L. In the case that the product could not be returned to the factory for checking and repairing, Lynx Pro Audio S.L. would supply all the necessary parts.

Lynx Pro Audio S.L. is not responsible for any damage or defect caused during the transport or caused by an undue or improper handling y a non-authorized person during the life of this guarantee.

All our products undergo rigorous tests and quality controls. We guarantee the characteristics described here within and their quality against any fabrication defect.

The user loses all warranty rights if he incorporates or carries out any modification to the product, if he uses it outside of the stated safe working loads or does not secure the system properly using all the pins in their corresponding holes.